

EXCELDirect Power Vent®

POWER VENT VENTING SYSTEM INSTALLATION AND MAINTENANCE INSTRUCTIONS

EXCELDirect Power Vent® is a certified venting system designed to be used only with certified direct vent gas-fired appliances.

The direct vent gas appliance must be certified for use with the ICC EXCELDirect Power Vent® venting system. Refer to the manufacturer's labelling and instruction manual to confirm that EXCELDirect Power Vent® is listed for use with the selected appliance model.

WARNING

- The installation must conform with local codes or, in the absence of local codes, with the following code in force:
 - National Fuel Gas Code, NFPA 54/ANSI Z223.1 (USA) or,
 - Natural Gas and Propane Installation Code, CAN/CSA B149.1 (Canada).
- A significant cause of vent-related fires is failure to maintain required clearances (air space) to combustible materials. The power vent gas appliance instructions manual indicates the venting configurations and clearance requirements. It is of utmost importance that this venting system is installed only in accordance with these instructions. Do not fill the air space with insulating material.
- A direct vent appliance must be connected to a single venting system. Multiple venting is not allowed.
- Specific requirements for horizontal installation, such as minimum clearances to a balcony, window, door, soffit, etc., are detailed in this manual.
- Contact local building or fire officials about restrictions and installation inspections in your area.
- Risk of fire or carbon monoxide poisoning due to joint separation or pipe breakage.

Do not begin installing the ICC EXCELDirect Power Vent® venting system until you have carefully read the appliance and vent system installation instructions.

Use only ICC model EXCELDirect Power Vent® parts. Failure to do so will void the certification and warranty of the product.

Keep this installation and operating instructions in a safe location for future reference.

EXCELDirect Power Vent® has been tested as per applicable requirements (Listing #: MH46076) to the following Standards:

- UL 1738; Venting Systems for Gas-Burning Appliances, Categories II, III, & IV
- UL 2112; Venting Systems for Use with Gas-Fired Direct Vent Appliances
- ULC-S636; Type BH Gas Venting Systems
- ANSI Z21.88 - CSA2.33; Vented Gas Fireplace Heaters



ICC INDUSTRIAL CHIMNEY COMPANY INC.

400 J.F. Kennedy, St. Jerome

Quebec, Canada, J7Y 4B7

Tel.: (450) 565-6336, Fax: (450) 565-65 19

www.icc-rsf.com

TPV-II_2023-10

TABLE OF CONTENTS

1.	Technical Specifications	3
2.	Operation and Maintenance	3
3.	General Installation Notes	4
4.	Planning Your Installation	4
4.1.	General	4
4.2.	Tool Checklist	5
4.3.	Rules of Safety	5
5.	Assembling Notes	6
5.1.	Use of Sealants	6
5.2.	Joint Connection	6
6.	Installation Instructions	8
6.1.	Horizontal Installation	8
6.2.	Vertical Installation	11
6.2.1.	Vertical Terminations	13
6.2.2.	Elbows and Offsets	13
6.3.	Installation Parts	15
6.3.1.	Floor and Attic Protection Parts	15
6.3.2.	Supports	17
7.	Power Vent In-line & End-line Fans	20
8.	Horizontal and Vertical Termination Location	21
9.	EXCELDirect Power Vent® Parts List	22
	LIMITED LIFETIME WARRANTY	23

⚠ WARNING:
FIRE OR EXPLOSION HAZARD
Failure to follow safety warnings exactly could result in serious injury, death, or property damage.

- Do not store or use gasoline or other flammable vapours and liquids in the vicinity of this or any other appliance.
- **WHAT TO DO IF YOU SMELL GAS**
 - Do not try to light any appliance.
 - Do not touch any electrical switch; do not use any phone in your building.
 - Leave the building immediately.
 - Immediately call your gas supplier from a neighbour's phone. Follow the gas supplier's instructions.
 - If you cannot reach your gas supplier, call the fire department.
- Installation and service must be performed by a qualified installer, service agency or the gas supplier.

1. Technical Specifications

Materials	
Outer Casing:	0.019" Galvalume
Inner Liner:	0.019" Type 444 Stainless Steel
Gaskets:	High-Temperature Silicone
Inner Liner Diameter	3 ¼"
Outer Casing Diameter	5"
Outer Casing Expanded Diameter	5 ⅜"
Weight/Foot (lb/ft.)	2.0
Allowable Flue Gas Temperatures	
UL 1738	550 °F (+ 70°F for ambient temperature)
Rough Opening Required	
*Base Support (BS), *Roof Support (SR)	7" x 7"
Firestop Ceiling Support (FS)	7" x 7"
Wall Thimble (WT, WTI)	7 ½" x 7 ½"
<small>*Rough opening required is for combustible construction. For non-combustible construction, the minimum opening required for vent to pass is 5 ¼" square or round.</small>	
Maximum Support Capacity	
Offset Support (OS) - Installed Horizontally or Inclined	4'
Roof Support (SR)	30'
Firestop Ceiling Support (FS)	30'
Base Support (BS)	40'
Adjustable Wall Support (WS)	30'
Horizontal Band (HB)	10'
Clearances	
Clearance to combustibles	Clearance to combustibles differs among various appliances. Consult the manual provided by the appliance manufacturer for requirements.

2. Operation and Maintenance

Initially, inspect the vent system weekly. From this, you will learn if your gas appliance needs fine-tuning. **KEEP YOUR VENT CLEAN.** When using a Direct Vent gas appliance, we recommend that your vent system is examined annually by a qualified service company for the following:

1. Verify the connection between the vent adapter and the appliance's first joint.
2. Remove the termination cap to ensure that no obstruction could block the air intake and flue exhaust.
3. Verify if there is a sign of corrosion.
4. Verify that the supports, flashing, and storm collar are correctly in place.
5. Check for signs of accumulating condensation.

3. General Installation Notes

1. EXCELDirect Power Vent® is a complete system extending from the appliance to the outdoors. This may include an in-line or end-line power vent fan from a listed appliance manufacturer. Please refer to the appliance manufacturer's installation instructions.
2. Each appliance must have its own separate EXCELDirect Power Vent® system.
3. For vent run distances and configuration requirements, please refer to the appliance and power vent fan manufacturer's manual.
4. Choose a gas appliance labelled as a recognized Listing Agency (such as INTERTEK (ETL), UL, ULC, CSA, PFS, and OMNI).
5. Install the gas appliance as described in the Installation Instructions accompanying the gas appliance.
 - BE CERTAIN TO MAINTAIN THE REQUIRED CLEARANCES TO COMBUSTIBLE MATERIALS.
6. The maximum height of a supported exposed vent Length (L) above the roof is 6'.
7. Portions of the vent which extend through accessible spaces shall be enclosed in all cases to avoid personal contact with the vent and damage to the vent.
8. DO NOT FILL THE AIR SPACE around the vent with insulation or other material. Do not fill the factory-built supports with insulation. Insulation placed in this area could cause adjacent combustibles to overheat.
9. Do not allow sawdust or construction debris to accumulate around the vent. Clean all areas surrounding the vent before closing any enclosed spaces.
10. In attics, clean the joist area around the vent before installing any support.
11. The Horizontal Terminations (HT) shall not be recessed into a wall or siding.
12. Examine all parts for shipping damage before installation. Check for proper joint construction when joining pipe to fittings.
13. This venting system must be free to expand and contract. Check for unrestricted vent movement through walls, ceilings, and roof penetrations. This venting system must be supported in accordance with these instructions.
14. If using category 3 or 4 appliances, check the joints and seams for leaks.

4. Planning Your Installation

4.1. General

Before starting your installation, be sure to consider the following:

1. There are two general ways to connect a direct vent venting system to a gas appliance:
 - Horizontal installation (through the wall)
 - Vertical installation (through the roof).
 - i. Check the appliance manufacturer's installation instructions to see all vent configurations.
2. Review all your options for the appliance location and venting configuration. Try to minimize the alteration and reframing of structural components of the building (wall studs, water pipes, electrical wiring, ceiling joists, roof rafters, etc.). It may be

easier to change the location of your appliance than to modify the building structure.

3. Carefully read the appliance and the venting system instruction manuals. Good planning might save you time, work, and money.
4. Use only authorized EXCELDirect Power Vent® listed parts unless compatibility with another brand is specified in the appliance manufacturer's instructions. Do not use damaged parts.
5. For a horizontal installation, consider the distance between the gas appliance adapter and the wall, the wall thickness, and a vertical rise (if applicable).
6. The exterior horizontal vent termination must be located per the Installation Codes and Regulations. See the "Horizontal and Vertical Termination Location" section on page 21.
7. For a vertical installation, you must consider the distance between the gas appliance outlet and the ceiling, the ceiling thickness, the height between floors, and allow sufficient vent height above the roof line. See Table 1 and Figure 8 on page 13.
8. For multi-story applications, firestops are required on each floor. Additional lengths and elbows will be required if an offset is needed in the attic.
9. Contact your local building authority and/or fire officials for permits, restrictions, and installation inspections. You may also wish to contact your house insurance representative.
10. Any sealants used must be used within their marked time limitations.

4.2. Tool Checklist

Tools and equipment you may need for your installation.

- Eye protection
- Stud sensor
- Ladder
- Hammer
- Gloves
- Square
- Level
- Screwdriver
- Tape Measure
- Circular saw
- Pliers
- Screws
- Extension cord
- Hand saw
- Caulking gun
- Plumb Bob
- Marking pencil
- Drill
- Hi-temp. Silicone sealant
- Cold chisel
- Nails
- Drill bits
- Keyhole saw

4.3. Rules of Safety

1. Wear gloves when handling metal parts with sharp edges.
2. Wear safety glasses.
3. Electrical tools must be grounded.
4. If a ladder is required, it must be in good condition, installed on a firm surface, and levelled.
5. When cutting a wall, floor, or ceiling, be careful not to damage wiring, gas, or water pipes. If these elements need to be relocated, work should be done by a qualified person.

5. Assembling Notes

5.1. Use of Sealants

EXCELDirect Power Vent® does not require sealant on any standard vent Length (L) joint, even if the appliance manufacturer specifies a sealant. The inner liner has a factory-installed high-temperature gasket on each Vent Length (L) that will make a sealed connection. However, certain accessory joints listed below require sealant. The outer casing has an O-ring which seals when compressed. A Locking Band (LB) is provided with each length to secure each joint.

5.2. Joint Connection

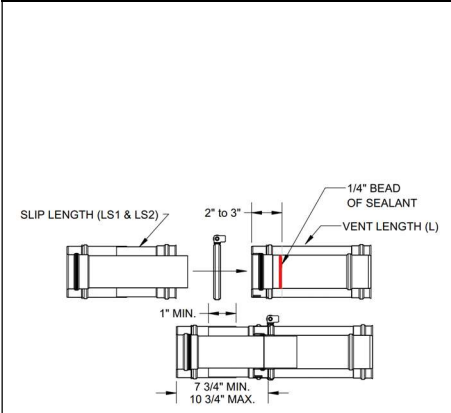
	<p>Slip Lengths (LS1, LS2) The EXCELDirect Power Vent® 12" Slip Length (LS1) adds 7 3/4" - 10 3/4" or 13 3/4" - 22 3/4" for the 24" Slip Length (LS2). To adjust the Slip Length, insert the inner liner to the desired location and slide the lower outer casing to the corresponding location. Then screw the two outer casings together (min. 1" overlap) with the three self-tapping screws (included). Be sure not to puncture the inner liner. To seal the outer casing, wrap the seam in a self-fusing silicone tape ("Caulking Roll," optional), aluminum tape or silicone.</p>
<p>Figure 1. Slip Length Assembly</p>	<p>Sealed Joints (LS1, LS2, FIA, FAD, FOA, MAD, R53, R43) Certain adapters require a small amount of sealant on the inner liner to make the joint airtight. Place a 1/4" bead of silicone on the interior of the inner liner, roughly 2-3" from the female end of the receiver vent Length (L) before installation.</p>

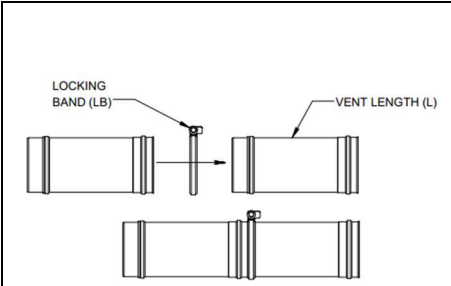
	<p>Vent Lengths (L) To connect two vent lengths, simply insert the male end of one part into the female end of the adjoining part and press firmly until the outer casings are fully inserted into one another. The O-ring should be barely visible and compressed when fully connected. Once the lengths are firmly joined, fasten the joint with the Locking Band (LB), which is secured using a 7/16" nut driver. You can put a small amount of liquid dish soap on each gasket to make it easier to assemble the vent. Do not use a petroleum-based lubricant.</p>
--	---

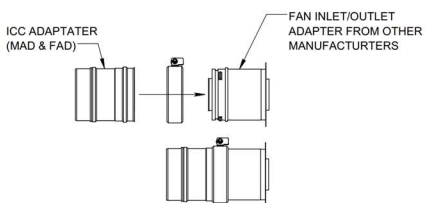

Figure 3. Fan Adapters from other manufacturers

Vent Length Adapters (MAD, FAD)

EXCELDirect Power Vent® has two universal adapters that are compatible specifically with certified fan or appliance outlet/inlet adapters from other manufacturers. Slide the Universal Male/Female Adapter (MAD, FAD) into fan or appliance inlet/outlet adapter. Once the adapters are firmly joined, fasten the joint with the adapter locking band (included), which is secured using a 7/16" nut driver. Apply a silicone sealant to seal the inner liner and outer casing. Refer to "Power Vent In-line & End-line Fans" on page 20 for more information on these adapters.

6. Installation Instructions

6.1. Horizontal Installation

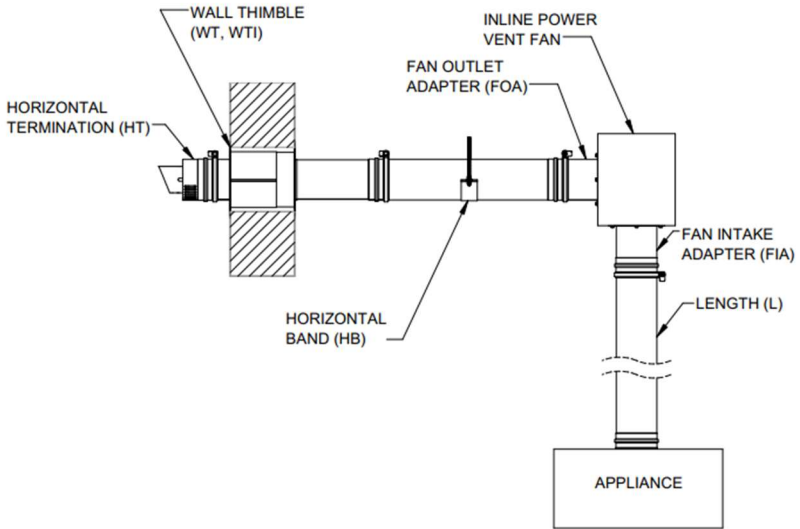

Figure 4. Horizontal Installations with in-line power vent fan

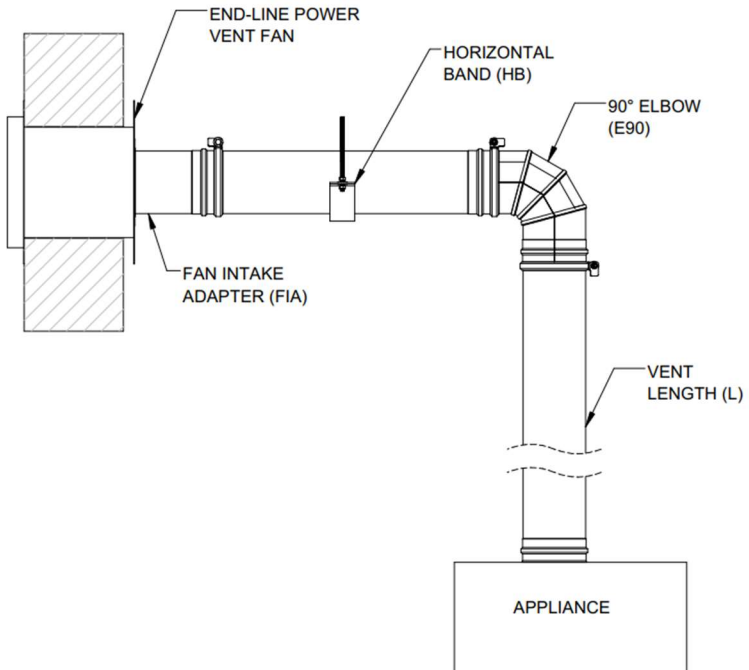

Figure 5. Horizontal Installation with end-line power vent fan

1. Determine a location for the appliance, venting, and termination that agrees with the codes and appliance manufacturer's requirements. See "Planning Your Installation" on page 4.
2. Venting configurations are specific to each gas appliance. The manufacturer's installation instructions will provide restrictions regarding maximum and minimum vent runs, the number of elbows and the relationships between lengths of vent run to vent rise.
3. EXCELDirect Power Vent® fits most standard appliance outlet collars without an adapter, but appliance adapters may be required for specific brands and applications. Insert the first length or adapter on the appliance outlet and fasten it to the appliance using the Locking Band (LB) provided.
4. The horizontal vent run must have a ¼" rise per linear foot of run towards the termination.
5. Move the gas appliance into its final position and mark the rough opening dimensions on the wall where the vent will pass. See the appliance manufacturer's installation instructions for exact clearance requirements for the Wall Thimble (WT, WTI). Cut and frame a hole in the interior and exterior wall, ensuring that the center of the hole is aligned with the center of the horizontal vent.
6. Install and fasten the remaining vent parts to achieve the desired layout.
7. If the installation is intended for an in-line power vent fan, install it at the desired location according to the manufacturer's installation instructions.
8. Insulated (WTI) and non-insulated (WT) wall thimbles are available with EXCELDirect Power Vent®. One must be installed every time a vent length passes through a wall. Refer to the appliance manual for requirements. The installation procedure is the same for both insulated and non-insulated parts.

- a. If you are going through a non-combustible wall (concrete wall, etc.), you do not need to install a Wall Thimble if proper clearances to combustibles are maintained around the vent.
- i. A round opening 6" diameter is sufficient to allow the vent to pass through a non-combustible wall. Seal the gap around the vent with the Firestop Plates (FSP) and sealant.

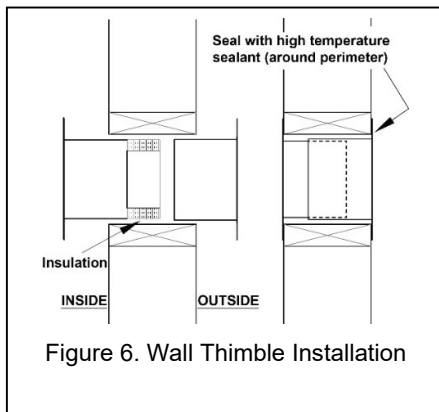

Figure 6. Wall Thimble Installation

9. If using a Wall Thimble, install the interior and exterior portions of the Wall Thimble (WT, WTI) and screw (or nail) them to the framed opening. If using the Insulated Wall Thimble (WT), the insulated portion goes inside the house (see Figure 6). Install the included Firestop Plates (FSP) around the vent length and screw it in using the included self-tapping screws.
 - a. The Wall Thimble ensures a 1" clearance to combustibles is maintained.

- b. It will fit a wall thickness from 5 ¾" to 10 ½". For wall thickness less than 5 ¾", cut both sleeves as required. Once installed, an overlap of 1" minimum is necessary.
10. Seal the perimeter of the exterior wall thimble using silicone sealant to prevent water infiltration and airflow between rooms.
11. At the outer wall, if installation is intended for an end-line power vent fan, install it at this point according to the manufacturer's installation instructions. Otherwise, install the final Wall Thimble (WT, WTI).
12. Pass the final Length (L) through the Wall Thimble (WT, WTI).
 - a. Ensure there is no joint between two vent Lengths (L) located inside the Wall Thimble (WT, WTI) because the Locking Band (LB) will not fit inside the Wall Thimble (WT, WTI) tubing.
13. From the outside, fasten the Horizontal Termination (HT) to the final vent Length (L) using the provided Locking Band (LB).
14. From inside, move the gas appliance into its final position, ensuring the vent Length (L) fully engages with the appliance outlet collar.
15. **Important: Firestop Plates (FSP) are required on the bottom of each floor installed from below and on each wall installed on both sides. See Figure 11 on page 16 for more information.**

6.2. Vertical Installation

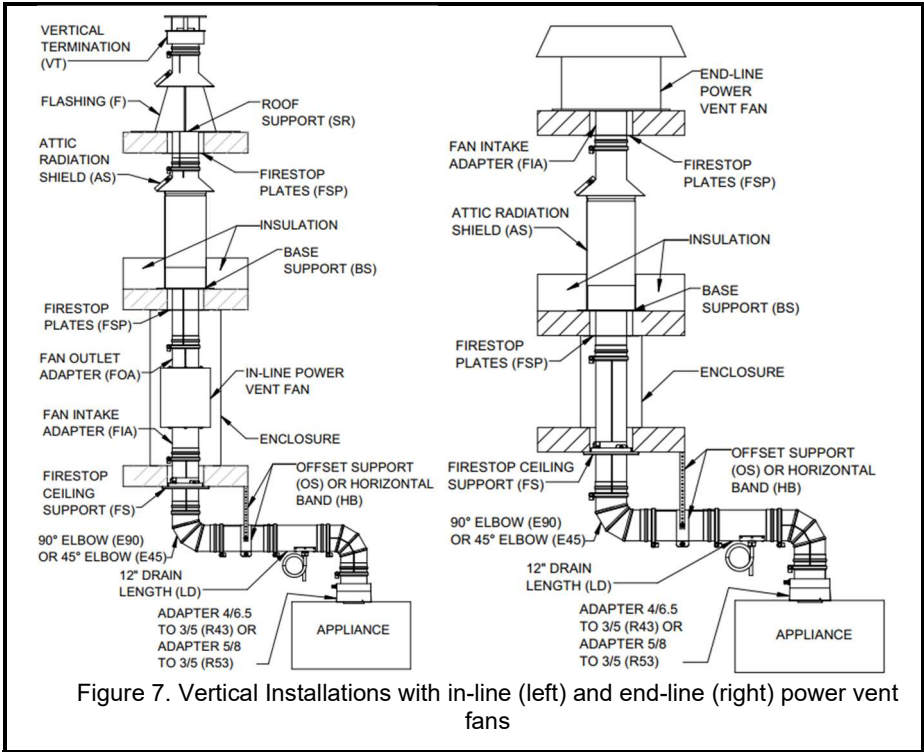

Figure 7. Vertical Installations with in-line (left) and end-line (right) power vent fans

1. Determine a location for the appliance, venting and termination that agrees with all the codes and appliance manufacturer's requirements. See "Planning Your Installation" on page 4.
2. Venting configurations are specific to each gas appliance. The manufacturer's installation instructions will provide restrictions regarding maximum and minimum vent runs, the number of elbows and the relationships between lengths of vent run to vent rise.
3. Place the gas appliance in its final position. Hold a plumb bob from the ceiling and align it with the centerline of the appliance flue outlet (or the first elbow if the appliance has a horizontal outlet). Mark the position on the ceiling. An offset will be required if there is an obstruction (e.g., framing). Refer to the section "Elbows and Offsets" on page 13 to determine the parts needed for the offset.
4. Refer to the "Supports" section on page 17 to choose the appropriate support for your application. The section "Technical Specifications" indicates the maximum support capacity on page 3.
 - **Important: Firestop Plates (FSP) are required on the bottom of each floor installed from below and on each wall installed on both sides. See Figure 11 on page 16 for more information.**
5. Cut and frame a hole in the ceiling to the dimensions indicated in the "Technical Specifications" section on page 3. Dimensions will vary depending on the type of

support used. See the appliance manufacturer's installation instructions for exact clearance requirements.

6. EXCELDirect Power Vent® fits most standard appliance outlet collars without an adapter, but appliance adapters may be required for specific brands and applications. Insert the first length or adapter on the appliance outlet and fasten it to the appliance using the Locking Band (LB) provided.
7. Continue adding and fastening vent parts until they reach the ceiling.
8. Install the desired support. See "Supports" starting on page 17 for full details on the available supports.
9. Proceed the same way if you must pass through other floors and install the necessary supports.
10. If the installation is intended for an In-line power vent fan, install it at this point according to the manufacturer's installation instructions.
11. Install an Attic Radiation Shield (AS) if the vent is not enclosed at the attic level. If the vent is enclosed in the attic, always keep at least 1" clearance to combustibles unless the gas appliance manufacturer's installation instructions specify different clearances.
12. Continue adding vent lengths through the roof until the required vent height extends to a point above the roof which complies with local or national code requirements and with the gas appliance manufacturer's installation instructions. See Table 1 on page 13.
13. If the installation is intended for an end-line power vent fan, install it at this point to complete the installation. Otherwise, continue with the remaining installation steps.
14. Install the appropriate roof flashing for your roof pitch. See Table 1 on page 13 for requirements. Seal the joint between the roof and the flashing with roofing tar or silicone sealant.
 - For slanted roofs, place the flashing under the upper shingles and on top of the lower shingles - approximately half of the flashing base should be under the shingles. Nail the flashing to the roof using roofing nails.
15. Place the storm collar over the vent and the flashing. Seal the storm collar to the venting with silicone sealant.
16. Fasten the Vertical Termination (VT) using the provided Locking Band (LB) to the final vent Length (L). See Table 1 on page 13 for minimum clearance.

6.2.1. Vertical Terminations

Vent lengths can run a maximum of 6' above the roof but need to be supported in one of the following ways:

1. Flat roofs
 - a. Base Support (BS)
 - b. Firestop Ceiling Support (FS)
2. Flat or pitched roofs
 - a. Roof Support (RS)

Flashing is also required with each of the previously mentioned support options. Vented (VF, VFA, VFB) and non-vented (F, FA, FB) flashings are available. Firestop Plates (FSP) are not required on the roof level but can be used for additional support. Refer to the appliance manufacturer's installation instructions for requirements.

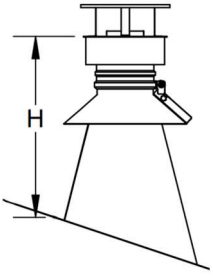
 <p>Figure 8. Vent Height Requirements for Roof Pitch</p>	Table 1. Minimum Recommended Vent Height		
	Roof Pitch	Minimum Height (H)	
		Feet	Meters
Flat to 7/12	1'	0.3	
Over 7/12 to 8/12	1 ½'	0.46	
Over 8/12 to 9/12	2'	0.61	
Over 9/12 to 10/12	2 ½"	0.76	
Over 10/12 to 11/12	3 ¼"	0.99	
Over 11/12 to 12/12	4'	1.22	

6.2.2. Elbows and Offsets

An offset will be required if the vent cannot pass directly above the appliance. Use Figure 9 and Table 2 to determine the parts needed. Use 30° or 45° elbows whenever possible instead of 90° elbows because they offer fewer restrictions.

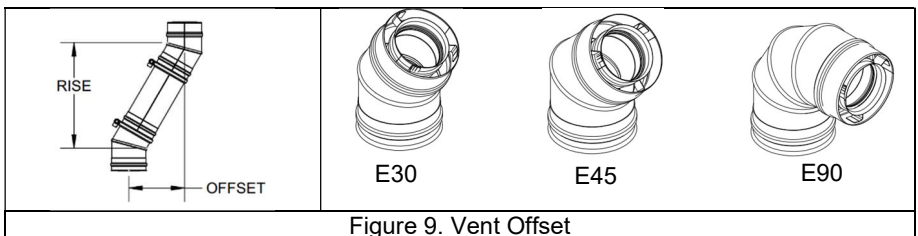

Table 2. Vent Offset Specifications

Part Configuration		30°		45°		90°	
		Offset	Rise	Offset	Rise	Offset	Rise
Single Length	No Length	3"	6 5/8"	4 5/8"	7 1/8"	11 3/8"	7"
	6"	5 1/8"	10 3/8"	7 1/2"	10"	15 1/2"	7"
	1'	8 1/8"	15 1/2"	11 3/4"	14 1/4"	21 1/2"	7"
	2'	14 1/8"	26"	20 1/2"	22 3/4"	33 1/2"	7"
	3'	20 1/8"	36 3/8"	27 3/4"	31 1/4"	45 1/2"	7"
	4'	26 1/8"	46 3/4"	37 1/4"	40"	57 1/2"	7"
Combination Of Lengths	1' + 6"	10 3/8"	19 1/4"	15 1/8"	17 1/2"	26 1/4"	7"
	2' + 6"	16 3/8"	29 5/8"	23 1/2"	26"	38 1/4"	7"
	3' + 6"	22 3/8"	40 1/8"	32"	34 1/2"	50 1/4"	7"
	4' + 6"	28 3/8"	50 3/8"	40 1/2"	43"	62 1/4"	7"
	4' + 1'	31 3/8"	55 5/8"	44 3/4"	47 1/4"	68 1/4"	7"
	4' + 1' + 6"	33 1/2"	59 3/8"	47 3/4"	50 1/4"	72 1/2"	7"
	4' + 2'	37 3/8"	66"	53 1/4"	55 3/4"	80 1/4"	7"
	4' + 2' + 6"	39 1/2"	69 3/4"	56 1/4"	58 3/4"	84 1/2"	7"
	4' + 3'	43 3/8"	76 3/8"	61 3/4"	64 1/4"	92 1/4"	7"
	4' + 3' + 6"	45 1/2"	80 1/8"	64 3/4"	67 1/4"	96 1/2"	7"
	4' + 4'	49 3/8"	86 3/4"	70 1/4"	72 5/8"	107 1/4"	7"
	4' + 4' + 6"	51 1/2"	90 1/2"	73 1/4"	75 3/4"	108 1/2"	7"

6.3. Installation Parts

12" Length with Drain (LD)

If an internal condensate drain is not part of the appliance but is required per the appliance manufacturer's instruction or local code, install a 12" Length with Drain (LD) as close as possible to the appliance. This drain section can be installed both horizontally and vertically. Refer to the appliance or power vent manufacturer's installation instructions for requirements concerning drainage.

When installed, the 12" Length with Drain (LD) section drain shall be located on the bottom side of the vent system (horizontal installation). A 1/2" diameter tube (not supplied) is used to direct the condensate to a floor drain. A trap loop must be formed in the drain hose and diameter at least four times the appliance's rated stack pressure in inches of water column or a minimum of 3 inches. Secure the loop with a cable tie. Before final assembly, the trap loop must be 'primed' by pouring a small quantity of water into the drain hose.

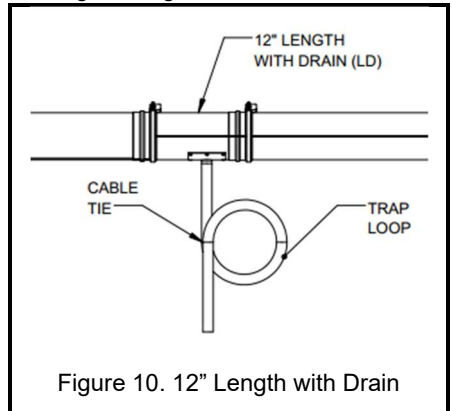

6.3.1. Floor and Attic Protection Parts

Firestop Plates (FSP) are required on every: ceiling (from below) or wall (interior and exterior) to prevent air and water flow between rooms or floors. The only place where Firestop Plates (FSP) are not required is at the roof level. EXCELDirect Power Vent® offers different firestop supports to fit all applications.

- On a horizontal installation, the Wall Thimble (WT, WTI) includes Firestop Plates (FSP) included (Figure 6). They are installed around the vent and screwed into the Wall Thimble (WT, WTI).
 - o In cases where the Wall Thimble is not required (only for 100% non-combustible walls), the Firestop Plates (FSP) alone can be used.
- On vertical installations, the Firestop Ceiling Support (FS) has the Firestop Plates (FSP) included and are screwed into the bottom plate of the Firestop Ceiling Support (FS). If a Base Support (BS) or other support is used, the Firestop Plates (FSP) are screwed directly into the roof joist.

Firestop Plates (FSP)

The Firestop Plates (FSP) come in two identical half-circular parts. **This part is required on the bottom of each floor installed from below and on each wall installed on both sides. See Figure 11 on page 16 for more information.**

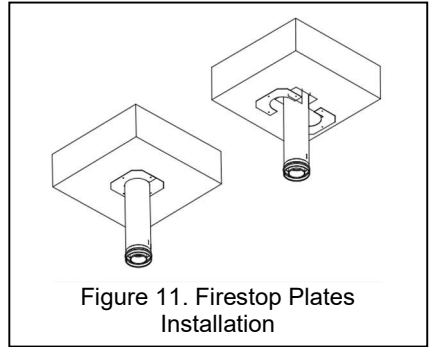

1. Place both parts around the vent length on the bottom side of the roof/ceiling so they overlap 2" to fully enclose the vent and cover any remaining gap.
 - a. There should no longer be any gaps for airflow around the vent, and the predrilled screw holes in the Firestop plates (FSP) should align, making installation easier.
2. Fix them in place by screwing them in using the included screws.

Attic Radiation Shield (AS)

The Attic Radiation Shield (AS) is used when the venting system is not enclosed in an attic space. This part is installed on the top of the floor level. Figure 12 shows an example.

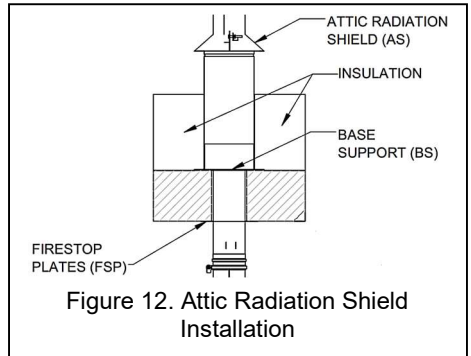

1. Screw the Attic Radiation Shield (AS) plate to the framed joist with four #8 x 1 1/2" wood screws.
2. The Attic Radiation Shield (AS) height is adjustable and is fixed at the desired height using the provided self-tapping screws.
3. The height (including Storm Collar (SC)) is adjustable from 17 3/8" to 32". A minimum of a 1" overlap is required. No sealant is required.
4. Place the Storm Collar (SC, included) around the vent Length (L) so that it is in contact with the top of the Attic Radiation Shield (AS) tube length. Tighten it in place. Ensure no insulation can enter the Attic Radiation Shield (AS).

Some supports are compatible with the Attic Radiation Shield (AS). The Base Support (BS) between the floor and the Attic Radiation Shield (AS), Firestop ceiling Support (FS) below the floor, or Firestop Plates (FSP) below the floor can be installed with the Attic Radiation Shield (AS).

Important: Firestop Plates (FSP) are required on the bottom of each floor installed from below and on each wall installed on both sides. See Figure 11 on page 16 for more information.

6.3.2. Supports

EXCELDirect Power Vent® has different supports for different applications. The “Technical Specifications” section on page 3 shows the maximum support capacity table for each type of support.

Horizontal Band (HB)

The Horizontal Band is a half band made of galvanized steel designed to support the vent when it travels horizontally. The maximum distance between Horizontal Bands is 10’.

Typically, ¼” diameter or larger threaded rods and fasteners (not supplied) are used to attach the band to the ceiling structure. Plumber strapping or any other hanging materials with a rating of 500 lbs or more can also be used.

Typical configurations are shown in Figure 13. Never puncture or screw through the vent Length (L), or any part.

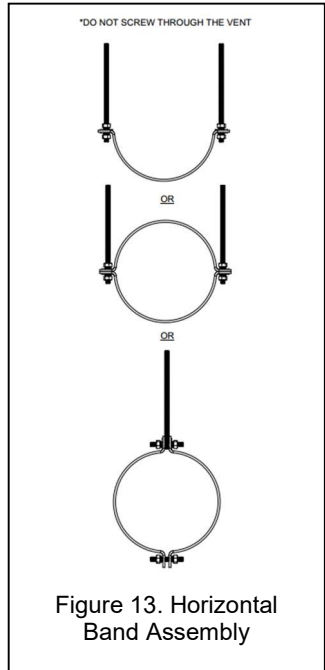

Figure 13. Horizontal Band Assembly

Wall Support (WS)

For vent runs that run parallel to a wall, a Wall Support (WS) is ideal. It is adjustable and can support vents that run 3 3/8” to 6 7/8” from the wall to the center of the vent. The Wall Support (WS) can also be used to support horizontal runs of venting.

1. Pre-assemble the universal support collar.
2. Install the support collar on the vent. Tighten the collar locking bolt just enough to hold it in place.
3. Attach the wall support brackets to the collar. They are slotted to allow them to adjust in and out. Adjust the brackets so the vent is parallel to the wall at the clearance specified by the appliance manufacturer’s installation instructions.
4. Fasten the wall support brackets to the wall in a convenient location. First, drive two #8 x 1 1/2” or larger screws into the slotted holes and two more into the round holes to rigidly fix the support in place.
5. Tighten the universal support collar around the vent Length (L).

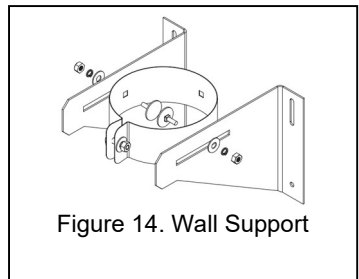

Figure 14. Wall Support

Firestop Ceiling Support (FS)

The Firestop Ceiling (FS) is designed to be used in wood framed construction and supports the vent from below the floor.

1. Cut and frame a 7" x 7" opening where the vent will pass.
2. Place a mark on the vent Length (L) that passes through the support at the location where it meets the support plate. This is where the Firestop Ceiling Support (FS) collar will be installed. Remove the length for the support collar to be installed.
3. Pre-assemble the support collar, as shown in Figure 15. Install the collar on the vent Length (L) that will pass through the support and tighten the locking bolt at your mark. Fasten the collar to the vent.
4. Install the Firestop Ceiling Support (FS) plate in the ceiling by screwing up through the four holes in the firestop. Do not over-tighten the screws. The raised edge of the firestop acts as a spacer and shouldn't be crushed.
5. Screw horizontally through the vertical standoffs with four #8 x 1 1/2" screws into the framing.
6. Pass the length with the collar through the support plate. The collar brackets should rest on the support plate.
7. Install the Firestop Plates (FSP) as described on page 16 by screwing them to the bottom plate of the Firestop Ceiling Support.

Important: Firestop Plates (FSP) are required on the bottom of each floor installed from below and on each wall installed on both sides. See Figure 11 on page 16 for more information.

Offset Support (OS)

When an offset is necessary for a vertical venting system (Figure 16), it is essential to support the vent Length (L) to avoid excessive stress on the elbows using the Offset Support (OS). The Offset Support (OS) can also be used to support horizontal runs of venting.

1. Pre-assemble the support collar as shown.
2. Install the support collar on the vent Length (L). Tighten the collar locking bolt just enough to hold the collar in place.
3. Fasten the strapping of the offset support to the framing with two #8 x 1 1/2" or larger screws on each strap and slide the collar to the appropriate location. See Figure 16.
4. Tighten the support collar around the vent Length (L).

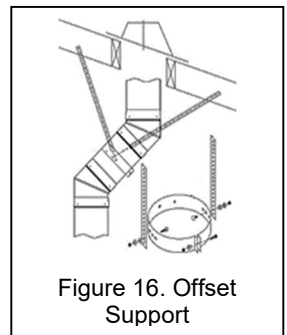
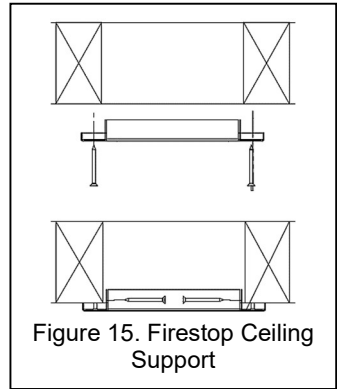

Base Support (BS)

The Base Support (BS) is the most common type of support installed. It can be used on any floor level, including non-combustible flooring. The Base Support (BS) can also be used to support horizontal runs of venting.

1. The vent Length (L) must first go through a floor opening before the support can be installed.
2. Push the two half plates against the vent Length (L) and screw them to the framing using five #8-1 1/2" screws or another appropriate fastener.
3. Put the support collar around the vent Length(L), so it is in contact with the top of the support base plate. Tighten the collar. Screw the support collar brackets to the support base using #10-1/2" or bigger sheet metal screws.

Important: Firestop Plates (FSP) are required on the bottom of each floor installed from below and on each wall installed on both sides. See Figure 11 on page 16 for more information.

Roof Support (SR)

The Roof Support (SR) may be used to support the vent Length (L) on a flat or inclined surface. The Roof Support (SR) can be installed either, so the collar is on the outside of the roof or so that it is set inside the roof hole.

Firestop Plates (FSP) are not required on the roof level but can be used for additional support. Refer to the appliance manufacturer's installation instructions for requirements.

1. Assemble the roof support collar.
2. Bolt on the two 90° roof support brackets. These brackets require two elevator bolts per bracket. Leave these bolts loose (See Figure 18).
3. Slip the support down over the vent Length (L). Locate the support on the vent so that the required amount of vent Length (L) projects below the finished ceiling.
4. Place the vent Length (L) in the opening of the roof. Rotate the 90° brackets to adjust for the roof pitch. Tighten the collar around the vent Length (L). Tighten the four nuts which hold the brackets to the support band.
5. Centre the vent Length (L) in the hole in the roof and nail or screw the support to the roof using up to twelve - 2 1/2" nails or # 8 X 1 1/2" wood screws.

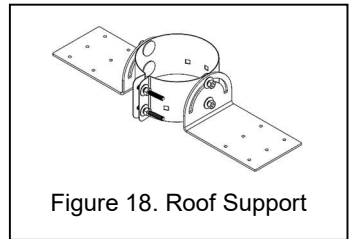
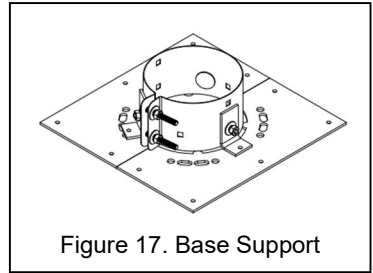

7. Power Vent In-line & End-line Fans

EXCELDirect Power Vent® is explicitly designed to be compatible with a power vent direct vent gas appliance and should only be used with certified gas appliances. Exhaust fumes are forced from the appliance through the inner liner outside while the power vent fan draws air through the outer casing to the appliance.

Two sets of EXCELDirect Power Vent® fan adapters are available to connect the vent Lengths (L) to the power vent fan shown in Figure 19.

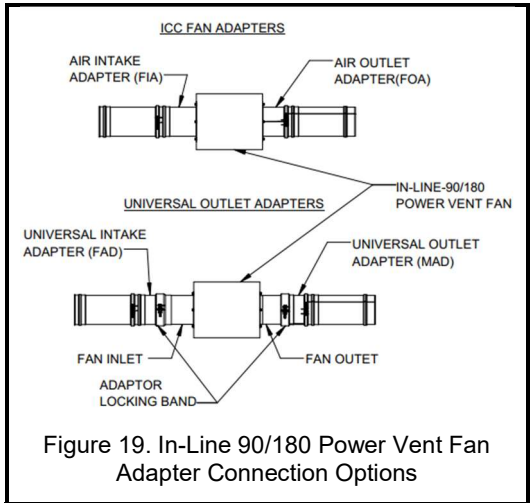

The Fan Outlet (FOA) and Fan Intake (FIA) Adapters can connect directly to the 3" x 5" power vent fan inlet and outlet. Only the Fan Intake Adapter (FIA) will be required for an end-line power vent fan. To seal the joint, silicone sealant must be applied on the bottom end of the inside of the inner liner and the bottom ring. The adapters are screwed to the power vent fan using the provided self-tapping screws. See Assembling Notes on page 6 for details.

Additionally, universal adapters are available that can connect from the certified manufacturers' appliance or fan inlets/outlets to EXCELDirect Power Vent®: Universal Outlet (MAD) and Universal Intake (FAD) Adapters. These adapters are secured using the included adapter locking band. Silicone will need to be applied to seal the joints. Refer to the appliance manufacturer's installation instructions for more information on Power Vent Fans and their required electrical connections.

8. Horizontal and Vertical Termination Location

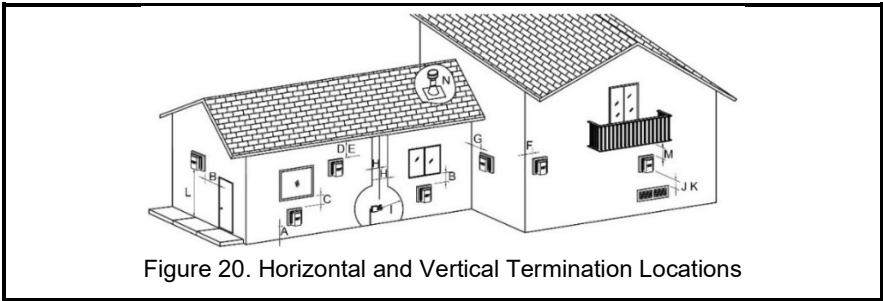

Figure 20. Horizontal and Vertical Termination Locations

Table 3. USA and Canadian Termination Installation Clearance

INSTALLATION			
	CANADIAN ¹	U.S.A ²	
A	12 in. (30 cm)	12 in. (30 cm)	Clearance above grade, veranda, porch, deck, or balcony.
B	36 in. (90 cm)	36 in. (90 cm)	Clearance to any building opening: window, door, etc.
C	12 in. (30 cm) ³	12 in. (30 cm) ³	Clearance to a permanently closed window.
D	18 in. (45 cm)	18 in. (45 cm)	Clearance to a ventilated soffit located above the termination within a horizontal distance of 2 feet from the centerline of the termination.
E	12 in. (30 cm)	12 in. (30 cm)	Clearance to an unventilated soffit.
F	As tested by appliance Manufacturer		Clearance to an outside corner.
G			Clearance to an inside corner.
H	36 in. (90cm)	36 in. (90cm) ⁴	Clearance to each side of the centerline extended above the meter/regulator assembly to a maximum vertical distance of 15 feet.
I	36 in. (90cm)	36 in. (90cm) ⁴	Clearance to service regulator vent outlet
J	12 in. (30 cm)	12 in. (30 cm)	Clearance to a non-mechanical air supply inlet to the building
K	6 feet (1.83m)	6 feet (1.83m)	Clearance to a mechanical air supply inlet or the combustion air inlet to any other appliance
L	7 feet (2.13m) ⁵	7 feet (2.13m) ⁴	Clearance above a paved sidewalk or a paved driveway located on public property.
M	12 in. (30 cm) ⁶	12 in. (30 cm) ⁴	Clearance under a veranda, porch, deck, or balcony.
N	---	---	Refer to Figure 8 and Table 1 on page 13
All terminations must be above the snowline in geographical areas where snow accumulates.			

¹ In conformity with the current Natural Gas and Propane Installation Code, CAN/CSA B149.1.

² In conformity with the current National Fuel Gas Code, ANSI Z223.1.

³ Recommended to prevent condensation on windows and thermal breakage.

⁴ This is a recommended distance. For additional requirements, check local code.

⁵ A vent shall not terminate above a sidewalk or paved driveway that is located between two single-family dwellings and serves both dwellings. For additional requirements, check local code.

⁶ Only permitted if veranda, porch, deck, or balcony is fully open on a minimum of 2 sides beneath the floor.

9. EXCELDirect Power Vent® Parts List

Part Name	Part Number	Code	Notes
Lengths and Elbows			
6" Length	TU-35DPL6	L	
12" Length	TU-35DPL1		
24" Length	TU-35DPL2		
36" Length	TU-35DPL3		
48" Length	TU-35DPL4		
12" Slip Length	TU-35DPLS1	LS1	Optional: Silicone caulking roll
24" Slip Length	TU-35DPLS2	LS2	
12" Length with Drain	TU-35DPLD	LD	
Elbow 30°	TV-35DPE30	E30	
Elbow 45°	TV-35DPE45	E45	
Elbow 90°	TV-35DPE90	E90	
Terminations			
Horizontal Termination	TX-35DPHT	HT	
Vertical Termination	TX-35DPVT	VT	
Supports and Firestops			
Wall Thimble	TX-35DPWT	WT	Includes: Firestop Plates (FSP)
Insulated Wall Thimble	TX-35DPWTI	WTI	
Firestop Ceiling Support	TX-35DPFS	FS	
Base Support	TX-35DPBS	BS	
Firestop Plates	TX-35DPFSP	FSP	
Wall Support	TX-35DPWS	WS	
Offset Support	TX-35DPOS	OS	
Roof Support	TX-35DPSR	SR	
Horizontal Band	TX-35DPHB	HB	
Attic Radiation Shield	TX-35DPAS	AS	Includes: Storm Collar (SC)
Adapters			
Fan Intake Adapter	TX-35DPFIA	FIA	
Fan Outlet Adapter	TX-35DPFOA	FOA	
Universal Female Adapter	TX-35DPFAD	FAD	
Universal Male Adapter	TX-35DPMAD	MAD	
Adapter 4/6.5 to 3/5	TX-35DPR43	R43	
Adapter 5/8 to 3/5	TX-35DPR53	R53	
Flashings and Locking Band			
Locking Band	TX-35DPLB	LB	Included with: All applicable parts
Storm Collar	TW-35DPSC	SC	
Flat Flashing	TW-35DPF	F	Includes: Storm Collar (SC)
1/12 - 7/12 Flashing	TW-35DPFA	FA	
8/12 - 12/12 Flashing	TW-35DPFB	FB	
Flat Vented Flashing	TW-35DPVF	VF	
1/12 - 7/12 Vented Flashing	TW-35DPVFA	VFA	
8/12 - 12/12 Vented Flashing	TW-35DPVFB	VFB	

LIMITED LIFETIME WARRANTY ICC EXCELDirect Power Vent® VENTING SYSTEM

ICC warrants its EXCELDirect Power Vent® venting system components to be free from functional failure due to defects in material or workmanship for as long as the original consumer owns the vent system. This warranty provides for the replacement of any vent components which fails as a result of normal use on a residential appliance. This warranty does not cover smoke damage or damage caused to the building by chimney fires or misuse of the product.

No claims under this warranty will be honoured unless ICC is notified of the potential claim and is given the opportunity to have one of its agents examine the vent system prior to replacement.

ICC will only be responsible for repair or replacement of any vent found to be defective under this warranty. In no event shall ICC be responsible for any incidental or consequential damage caused by defects in the EXCELDirect Power Vent® venting system.

During the first five years of the warranty, ICC will provide replacement vent lengths at no charge. During the balance of the warranty, ICC will provide replacement vent lengths at 50% of the current retail price at the time of the warranty claim.

ICC will not be responsible for labour of any kind required in the removal or replacement of an EXCELDirect Power Vent® system replaced under this warranty.

This venting system is designed to vent residential Gas-Fired Direct Vent gas appliances which are certified for use with the EXCELDirect Power Vent® venting system. This warranty is void if the venting system is used in an application for which it is not designed.

The EXCELDirect Power Vent® venting system must be installed according to the Installation Instructions included with every system at the time of purchase. If you do not have a set of installation instructions, they are available free upon request. This warranty is void if the venting system is not installed according to the installation instructions.

This warranty may not be extended or modified by our agents or representatives. This warranty is in lieu of all other express warranties or guarantees, of any kind.

