

Owner's Manual

Residential Factory Built Fireplace

Operation • Maintenance • Installation

OPEL PLUS KEYSTONE

Keep these instructions for future use.



Industrial Chimney Company Inc.
400 J.-F. Kennedy, St-Jerome, QC, Canada, J7Y 4B7
Telephone: (450) 565-6336
www.icc-rsf.com

RSF-IIPPK_2023-05

Dear Customer,

The OPEL+ KEYSTONE incorporates technology with elegance to give you a beautiful view of the fire without compromising on heating efficiency or environmental quality.

We have designed your new OPEL+ KEYSTONE to be easy to install, operate and maintain. It is in your best interest to become familiar with it. Study your manual to be sure that the installation is correct, then follow the guidelines for operation and maintenance.

We at **RSF Woodburning Fireplaces** congratulate you on your choice of the OPEL+ KEYSTONE, and are confident that you have purchased a fireplace that is *simply, the best*.

Sincerely,

RSF Woodburning Fireplaces Team

June 2018

TABLE OF CONTENTS

SAFETY FIRST	3	DOOR SEAL	16
Do's AND DON'TS	3	DOOR ADJUSTMENT	16
CREOSOTE: FORMATION AND REMOVAL	3	INSTALLATION	17
GENERAL SPECIFICATIONS	4	LOCATION	17
THE COMBUSTION CONTROL SYSTEM	4	CEILING CLEARANCE	20
CATALYTIC COMBUSTOR	4	STANDOFFS INSTALLATION	20
OPTIONS	4	SECURING THE FIREPLACE IN PLACE	20
UNIT DIMENSIONS AND CLEARANCES	7	FRAMING	20
OPERATION	9	OUTSIDE AIR DUCT	20
AIR CONTROLS	9	CHIMNEY	21
IMPROVING EFFICIENCY	10	CHIMNEY INSTALLATION	22
IMPORTANCE OF DRAFT	10	OFFSET CHIMNEY	23
VISIBLE SMOKE	10	CHASE ENCLOSURE	24
BURN TIME VS. HEAT OUTPUT	10	MASONRY CHIMNEY	24
FUEL	10	FINISHING AROUND THE FIREPLACE	26
FIRST FIRES	11	MANDATORY OPTIONS WITH TOP LOUVER BLOCKED	26
LIGHTING	11	HEARTH EXTENSION	26
ENGAGE THE CATALYST	11	BENEATH HEARTH EXTENSION	26
CATALYST TEMPERATURE PROBE	12	MANTEL	27
ADJUSTING THE BURN RATE	12	REFRACTORY BRICKS' INSTALLATION	27
REFUELING	12	GAS LOG INSTALLATION	28
TROUBLESHOOTING PROBLEMS	12	LISTING LABEL	29
MAINTENANCE	13	COMPLETE OPTIONS LIST	30
CATALYTIC COMBUSTOR	13	CONFIGURED OPTIONS LIST	32
REPLACING THE CATALYST	13	REPLACEMENT PARTS	33
CHIMNEY CLEANING	14	LIMITED WARRANTY	34
DISPOSAL OF ASHES	14		
GENERAL CLEANING	14		
PAINT	14		
GLASS CLEANING	14		
FACEPLATE REMOVAL	14		

SAFETY FIRST

DO'S AND DON'TS

If this fireplace is not properly installed, a house fire could result. For your safety, follow the installation directions. Contact your local authority having jurisdiction (such as municipal building department, fire department, fire prevention bureau, etc.) regarding restrictions and installation requirements, and the need to obtain a permit.

To ANYONE using this fireplace: these **DO's** and **DO NOTs** are for your safety.

1. **DO** read this instruction manual before lighting your first fire.
2. **DO** burn seasoned wood fuel, densified fuel logs wood fuel or a combination of densified fuel logs and wood fuel.
3. **DO operate the fireplace with the door either fully closed.** If the door is left partly open, gas and flame can be drawn out of the fireplace opening, creating both fire and smoke hazards.
4. **DO** keep all combustible materials (furniture, firewood, etc.) at least 4' away from the front of the fireplace.
5. This fireplace contains a catalytic combustor, which needs periodic inspection and replacement for proper operation. It is against federal regulations to operate this wood heater in a manner inconsistent with operating instructions in this manual, or if the catalytic element is deactivated or removed. **DO** learn to properly use the catalytic combustor and properly maintain it.
6. **Do** have at least one smoke detector on each level of the house and at least one carbon monoxide detector.
7. To avoid glass breakage, **DO NOT** slam the fireplace door.
8. **DO NOT** ever use gasoline, gasoline-type lantern fuel, kerosene, charcoal lighter fluid or similar liquids to start or freshen up a fire in this fireplace. Keep all such liquids well away from the fireplace while it is in use.
9. **DO NOT overfire the fireplace. If you are unable to slow down the burning rate of the fire or if the chimney connector behind the top louver glows red, you are overfiring the fireplace.**
10. **DO NOT** use a fireplace grate or other products not specified for use with this fireplace.
11. This wood heater has a manufacturer-set minimum low burn rate that must not be altered. It is against federal regulations to alter this setting or otherwise operate this wood heater in a manner inconsistent with operating instructions in this manual. The burn rates are set by the semi-automatic air control at the factory. **DO NOT** tamper with the air control. **DO NOT** install a flue damper that would allow you to reduce the chimney draft and thus slow the minimum burn rate.
12. **DO NOT** burn chemical chimney cleaners. They contain contaminants that will render the catalyst inoperative.
13. To avoid damaging the catalytic combustor, **DO NOT** operate this fireplace in a manner inconsistent with the operating instructions in this manual.
14. **DO NOT** operate this fireplace if the catalytic combustor is deactivated or removed, it is against the law.
15. **DO NOT** install an insert in this fireplace.



◆ **NOTE:** We strongly recommend that our products be installed and serviced by professionals who are certified by the National Fireplace Institute in the U.S. or by Wood Energy Technology Transfer Inc. in Canada.



CREOSOTE: FORMATION AND REMOVAL

When wood is burned slowly, it produces tar and other organic vapors which combine with the expelled moisture from the wood to form creosote. The creosote vapors can condense in the relatively cool chimney of a slow burning fire. As a result, creosote residue accumulates on the flue lining. When ignited, this creosote makes an extremely hot fire.

The chimney should be inspected periodically during the heating season to see if a creosote build-up has occurred. The presence in a chimney of soot or creosote in excess of 1/8" (3mm) thick will indicate the need for immediate cleaning, possible modification of burning procedures, and more frequent inspections.

❖ **WARNING: BURN DRY WOOD ONLY.**

DO NOT BURN: DRIFTWOOD, TREATED WOOD, COAL, GARBAGE, OR PLASTIC.

Do not use construction scraps (e.g. 2x4 or plywood scraps) as your only supply of fuel as you can overheat and seriously damage the fireplace.

We do not recommend using wax fuel logs (e.g. Duraflame) in this fireplace because it will dirty the glass. If you choose to use them, do not use more than one at a time and do not poke or stir while it is burning. Use only firelogs that have been evaluated for fireplace use. In Canada, they must meet the requirements of ANSI/CAN/UL/Ulc 2115, Processed Solid Fuel Firelogs and Firestarters. Refer to the firelog warnings and caution markings on packaging prior to use.

GENERAL SPECIFICATIONS

The OPEL+ KEYSTONE is environmentally friendly and complies with the 2020 United States Environmental Protection Agency (EPA) particulate emission standard with crib wood at an emission rate of 0.7 grams per hour.

The OPEL+ KEYSTONE has an overall efficiency of 70% with a maximum heat output of 27 034 BTU/hr. These results were measured in a test lab environment and were established using the higher heating value of the wood, as well as data from a crib wood EPA emission test and using CSA B415.1-10 calculations.

Consumers may experience different results. It has been demonstrated in a test laboratory that the heat output range varies with the type of installation, chimney height, cordwood used, etc. Please refer to the "Improving Efficiency", the "Importance of Draft", the "Burn Time vs. Heat Output" and the "Fuel" sections to better understand the various factors that influence the efficiency and heat output of your fireplace.

THE COMBUSTION CONTROL SYSTEM

Since the door is sealed, all combustion air must come through the OPEL+ KEYSTONE's draft control. This control has a bimetal coil to allow more air when the unit is cold, and less air when the unit is hot, guarding against overheating. It can be controlled either manually with the lever that is located on the right below the door, or automatically with an optional electric wall thermostat.

For the first few days, it is best to operate the fireplace with the manual control fully open (moved to the right as far as possible). Just control the fire as you would any normal fireplace, using one or two logs at a time for a smaller fire, or more logs for more heat. Once you become familiar with operating the fireplace with the control open, you can start experimenting with lower settings. Remember: when the fireplace is hot, the control will not need as much movement to reduce the fire as when it is cold. The bimetal coil will already have shut the damper part way. See the "OPERATION" section for the details.

CATALYTIC COMBUSTOR

The OPEL+ KEYSTONE is equipped with a catalyst. It ignites creosote-forming gases in wood smoke at significantly lower temperatures. As a result, you get less creosote and more heat from your fire at low to medium burn rates. Less fuel goes up your chimney in the form of smoke.

If the smoke that passes through the catalyst is not hot enough (at least 150°C-300°F), it will accumulate soot, reduce performance and increase the maintenance required. Opening the bypass allows smoke to exit the chimney while bypassing the catalyst. The bypass should always remain open when lighting a new fire or reloading a fire.

DO NOT burn chemical chimney cleaners, as they can contain contaminants that will render the catalyst inoperative. See the "OPERATION" section for the details.

OPTIONS

Louver Options

Without the Keystone Top Louver

When the OPEL+ KEYSTONE is installed without the upper Keystone Louver, two Gravity Vent Kits (see "

Gravity vent Options" below) are required on top of the fireplace for hot air circulation.

With the Keystone Top Louver (FO-OPLK)

When the Keystone Louver is installed, no gravity vents are required. Hot air circulation will flow out of the Keystone Louver. Gravity vents remain optional, but are not mandatory in this configuration.

Gravity vent Options

Gravity vent kits allow hot air to be ducted from the fireplace to a room above or on the same level as the fireplace. OPEL+ KEYSTONE installations without the Keystone Top Louver require two gravity vents for heat circulation.

Each gravity vent kit includes 5' of insulated flexible ducting, a fireplace adapter, an outlet grill adapter, and a decorative outlet grill.

Additional 5' lengths of insulated flexible ducting can be ordered with the part code FO-DUCT5. Nevertheless, gravity vents have a maximum length of 15'.

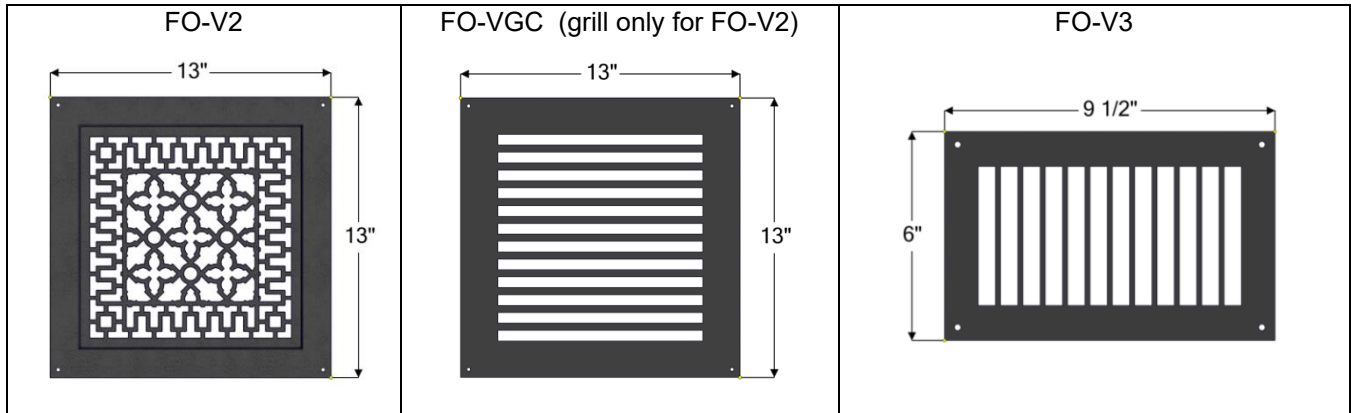

Heating Options

Internal Blower

For increased air circulation and marginally more heat output, you can add the Circulating Internal Blower (FO-HB9) to your Louvered OPEL+ KEYSTONE.

Central Heat Blower

For constant heat, day and night, you will be surprised by what the Thermostat Option (FO-FDHC4) can do for you. This option provides you with the necessary parts to automatically control the draft control via a wall thermostat. It will keep your room temperature as even as though you were heating with oil, gas or electricity, except you will find wood heat more comfortable.

To maximize the distribution of the heat generated by your OPEL+ KEYSTONE fireplace throughout many rooms and different floors, consider the Central Heat Option. With our Central Heat Blower (FO-FDHB6-1), you can use ducts to circulate the fireplace heat to one or many rooms. The Central Heat Control (FO-FDHC6) will enable automatic control of the Central Heat Blower via a wall thermostat and thermal switch. The Zone Heat Control (FO-FDHCZ1) along with Zone Damper Kits (FO-FDHCZ2) will provide the same features as the Central Heat Control but for more than one heating zone. If you wish to install the Central Heat Blower on a Clean Face OPEL+ KEYSTONE, you will need the Central Heat T (FO-T) that will enable you to connect the central heat duct along with the left gravity vent on the fireplace.

Heat Dump

For a simpler way to circulate a moderate amount of warm air from the fireplace to another room, we offer the Heat Dump Kit (FO-HD) which uses a smaller fan than the Central Heat Blower. It is most often used to provide supplemental heating to a basement room when the fireplace is on the main floor but it can also be used to send the warm air upstairs.

General Options

Rock Retainer Kit

To simplify the installation of thin non-combustible materials such as ceramic tile or sliced brick, we have designed a very versatile rock retainer kit (FO-KK). It is not designed or required for full brick or stone. Thin materials can

also be installed directly on the face of the OPEL+ KEYSTONE using high temperature silicone as glue, without a rock retainer kit.

Ash Pan

To remove accumulated ashes from the firebox, simply shovel them in to a metal container. Nevertheless, you may find the optional Ash Pan Kit (FO-AP) very convenient. You remove the plug from the firebox and sweep the ashes into a hole to the ash pan. When the ash pan is full, simply remove the ash pan by the bottom louver and dispose of the ashes properly.

◆ **NOTE:** Many options require wiring and/or electricity for their installation. If there is any chance that any of these options will be installed in the future then suitable wiring should be run during framing. Otherwise, it will be difficult to install these options later. You can refer to page 30 for a list of options that require electricity.

Detailed installation instructions are included in the box with each option. These can also be obtained from our Internet Web Site: www.icc-rsf.com.

❖ **WARNING: THIS FIREPLACE HAS NOT BEEN TESTED WITH AN UNVENTED GAS LOG SET. TO REDUCE RISK OF FIRE OR INJURY, DO NOT INSTALL AN UNVENTED GAS LOG SET INTO THIS FIREPLACE. DO NOT INSTALL A GAS LOG LIGHTER BECAUSE THE HEAT PRODUCED BY THE FIREPLACE WILL PERMANENTLY DAMAGE THE GAS LOG LIGHTER.**

UNIT DIMENSIONS AND CLEARANCES

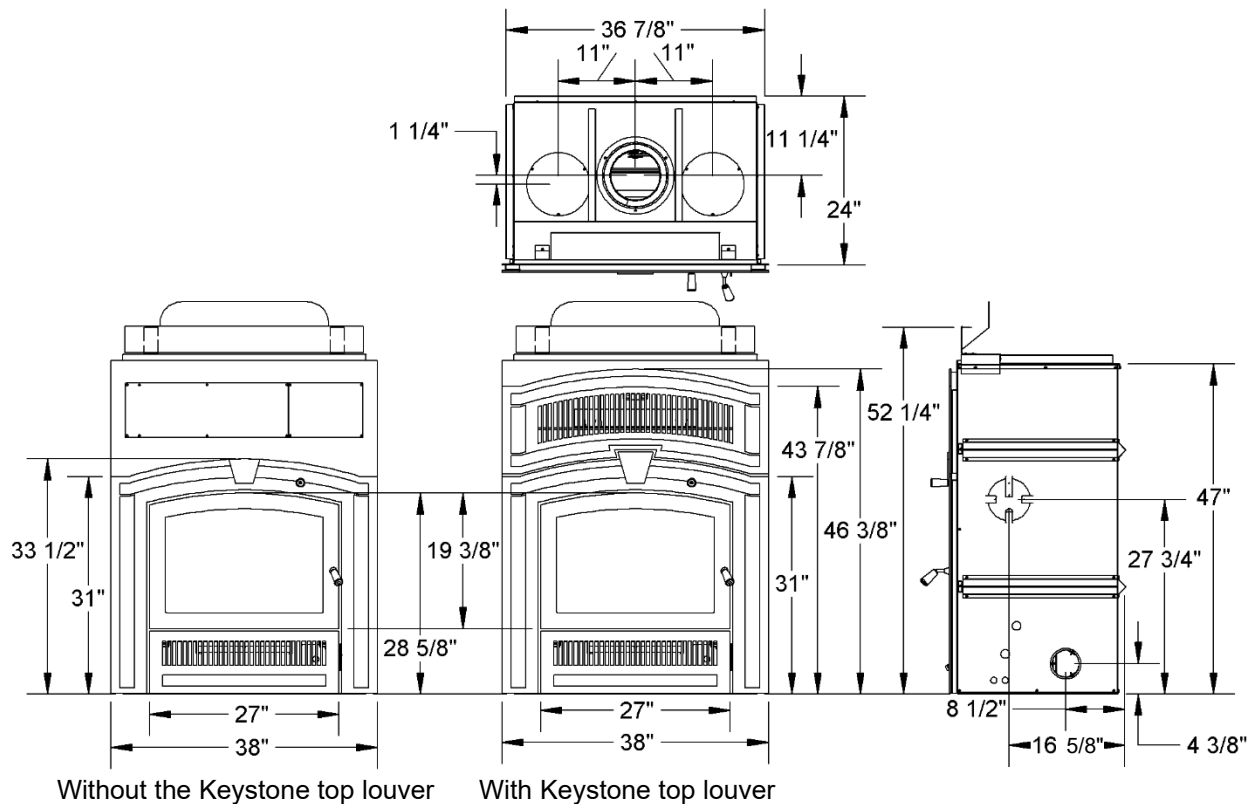
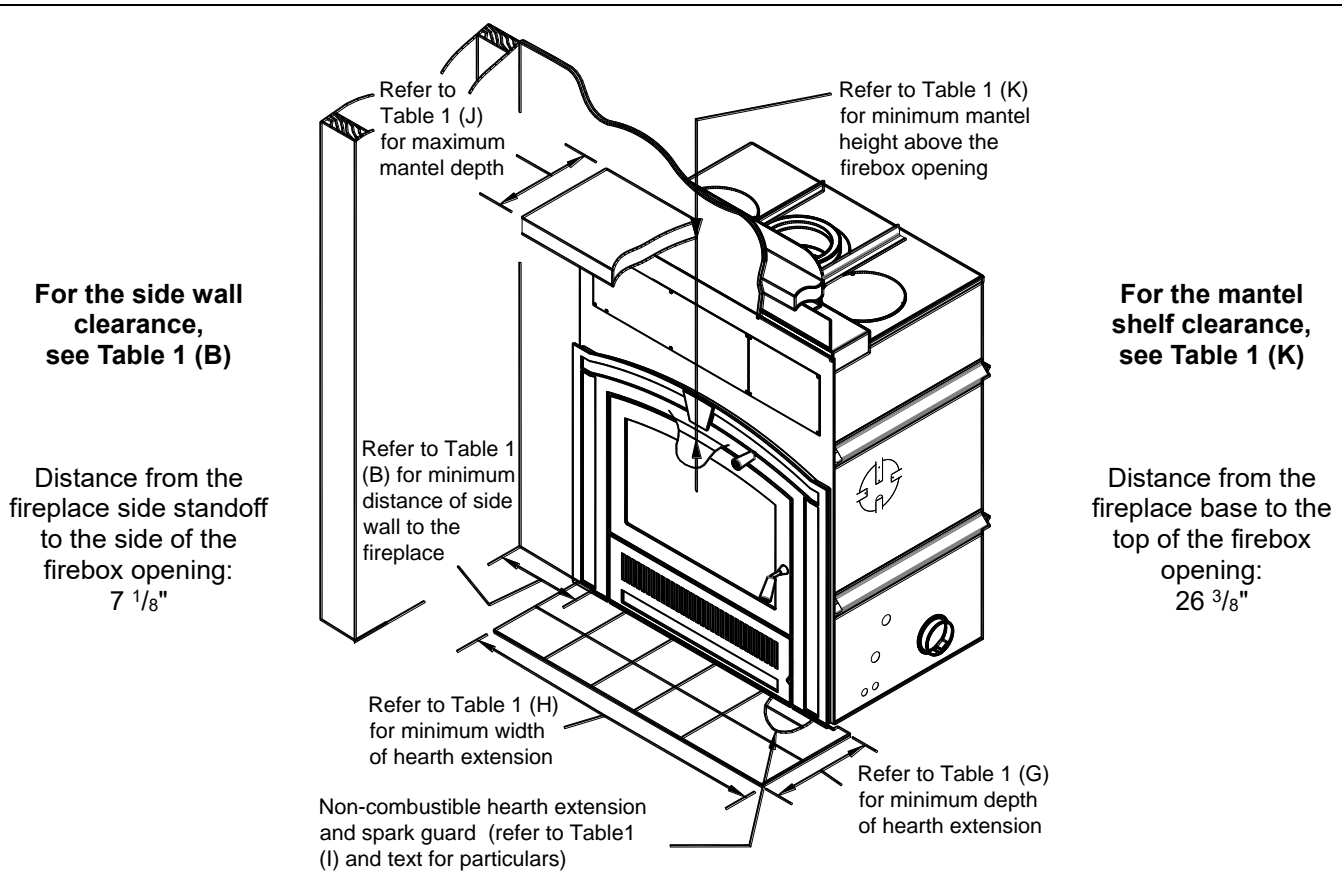

Figure 1 Unit Dimensions and Clearances

❖ **WARNING: COMBUSTIBLE FRAMING IS NOT PERMITTED IN THE SPACE DIRECTLY ABOVE THE FIREPLACE. THE ONLY EXCEPTION IS FOR FRAMING USED TO SUPPORT THE FACING MATERIAL AND MANTEL. THE AREA ABOVE THE FIREPLACE MUST BE FREE OF COMBUSTIBLES FOR AT LEAST THE HEIGHT PROVIDED IN TABLE 1(C).**

Table 1 Unit Dimensions and Clearances

A	Distance of combustible material from side, back and top standoffs	0" (0,0 mm)
B	Minimum distance of side wall to the side of the firebox opening	16" (406 mm)
C	Minimum ceiling height: measured from the base of the fireplace to the lowest point of the ceiling above the fireplace. Applies both to the inside and outside of the fireplace enclosure.	sealed enclosure 7' (2,13 m)
		vented enclosure 6' (1,83 m)
D	Minimum chimney height: minimum total chimney height from fireplace top to below the chimney rain cap	12' (3,66 m)
E	Maximum chimney height: maximum total chimney height from fireplace top to below the chimney rain cap	40' (12,19 m)
F	Maximum chimney height supported by the fireplace	18' (5,47 m)
G	Minimum depth of non-combustible hearth extension: from the front of the fireplace	18" (457 mm)
H	Minimum width of non-combustible hearth extension: total width, must be centered on the firebox opening	42" (1,07 m)
I	Minimum width of the spark guard	36" (914 mm)
J	Maximum mantel depth (see Table 2 for other mantel sizes)	12" (305 mm)
K	Minimum height of a combustible mantel above the top of the firebox opening: from the highest point of the firebox opening to below the combustible mantel (see Table 2 for other installation heights) (refer to the "Installation: Mantel" section for particulars)	36 ½" (927 mm)
L	Minimum distance of combustible wall materials above the fireplace facing from the firebox opening (other than the combustible mantel shelf, see J and K above)	39 ¼" (997 mm)

Table 2 Various Mantel Depths and Corresponding Installation Heights

Maximum Mantel Depth	Minimum Installation Height
0" to 4"	32"
6"	33 1/8"
8"	34 1/4"
10"	35 3/8"
12"	36 1/2"

No combustible mantel can be installed lower than 32" above the top of the firebox opening. A combustible mantel cannot be wider than 12".

For combustible mantel depths not mentioned in the list above, you can interpolate the minimum installation height between the two closest mantel depths. For example:

- Mantel depth to be installed: **9 1/4"**
- It is between 8" and 10" with corresponding installation heights of 34 1/4" and 35 3/8"
- So: $((9.25 - 8) / (10 - 8)) \times (35.375 - 34.25) + 34.25 = 34.95 = 35"$
- Minimum installation height of a **9 1/4"** mantel: **35"** above the firebox opening.

If the combustible mantel has a cross-section with variable depth, it must be installed so that its widest part is not installed lower than the corresponding minimum installation height while making sure that the lowest point of the mantel is not installed lower than the minimum installation height corresponding to its depth.

Refer to the "Installation: Mantel" section for details.

OPERATION

AIR CONTROLS

Unlike most open fireplaces, RSF fireplaces don't have flue dampers. Instead, the system is sealed by closing the door, and the amount of air entering the firebox is controlled by the combustion air control lever on the front of the fireplace on the right below the door (see Figure 2) which can be moved up or down. Setting the air control lever all the way open (up) will allow the maximum amount of air into the firebox. Closing the air control (down) will reduce the amount of air entering the firebox. This will slow the fire and extend the burn time (see section Adjusting the Burn Rate for details).

Bi-metallic Damper

The bi-metallic damper is a unique feature built into your OPEL+ KEYSTONE fireplace. As the fireplace heats up it will activate the bi-metallic damper. This will automatically begin to shut down the air entering the firebox, slowing the combustion process. This will save you wood in the long run, and prevent the fireplace from overheating and causing potential damage to the firebox. **We suggest that the combustion air control lever is used as the primary control to limit the oxygen entering the firebox, and that the bi-metallic damper is left as an additional safety system.**

Outside Air Control

The OPEL+ KEYSTONE has been designed to offer you the choice to use outside air or inside air for combustion. You will find a sliding door behind the bottom louver and below the firebox. Push the sliding door towards the back

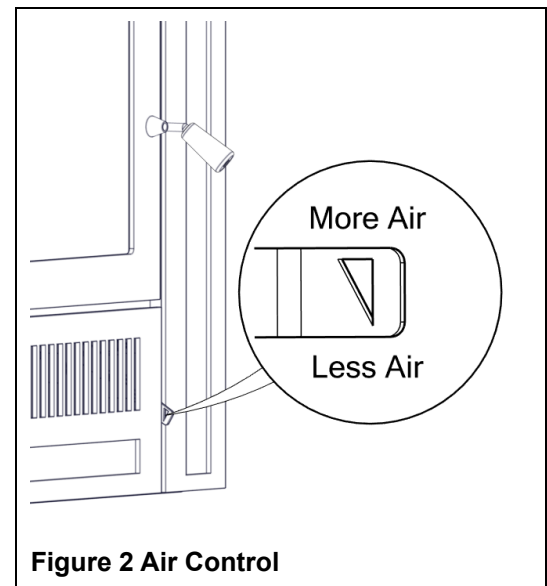

Figure 2 Air Control

to select outside air or pull it toward the front to select inside air as the combustion air. Because outside air is generally colder and denser it will help to start the fire. In some cases, this fresh air will also help compensate for negative pressure problems within the house; however, it will not prevent the fireplace from smoking in a severely depressurized house.

IMPROVING EFFICIENCY

The location of your fireplace will affect how efficiently it heats the home. Your fireplace should be located in part of the house you want to be the warmest. Trying to heat the main floor with a fireplace in the basement will generally overheat the basement and waste fuel. Certain RSF options offer the ability to move heat from the main floor to the basement. This allows you to efficiently heat your primary space while also heating the basement as a secondary space.

The efficiency can also be influenced by various factors such as the draft in the chimney (refer to "Importance of Draft" below), the amount of wood burning at any point (see "Burn Time vs. Heat Output" below) and the quality of the wood (refer to "Fuel" below).

All of these factors must be considered and optimized in order to recover the maximum heat from your fireplace.

IMPORTANCE OF DRAFT

Draft is the natural force which pulls air from the fireplace up the chimney. The strength of draft in your chimney depends on a variety of factors, including chimney height, nearby obstructions, altitude, etc.

Excessive draft can result in a hotter fire than intended or reduced burn times as more air is pulled through the fireplace. It will also result in less heat recovery since the heat will not have as much time to irradiate into the room before being sucked into the chimney.

Weak draft can result in smoke entering the room and difficulty lighting or operating the fireplace. Weak draft is often incorrectly associated as a blockage in the air intake for the fireplace. Adding chimney height is the most common solution. See Table 3 for minimum chimney height recommendations.

VISIBLE SMOKE

The amount of visible smoke being produced can be an effective method of determining how efficiently the combustion process is taking place in the given settings. Visible smoke consists of unburned fuel and moisture leaving your stove. Learn to adjust the air settings of your specific unit to produce the smallest amount of visible smoke. Wood that has not been seasoned properly and has a high wood moisture content will produce excess visible smoke and burn poorly.

Burning wood naturally produces smoke and carbon monoxide (CO) emissions. CO is a poisonous gas when exposed to elevated concentrations for extended periods. This fireplace combustion system reduces the amount of CO emitted out the chimney. Exposure to the gases in closed or confined areas can be dangerous. Make sure your door gasket is sealing properly and chimney joints are in good conditions to ensure unintended exposure. It is recommended that you use both smoke and CO detectors in areas having the potential to generate CO.

BURN TIME VS. HEAT OUTPUT

The faster your fireplace burns the more heat it will create; however, faster fires result in much more hot air flow up the chimney which means you are sacrificing efficiency. Fast burning fires (lots of air) go through much more wood than slow burning fires. To get the most out of your OPEL+ KEYSTONE fireplace, adequately adjust the combustion air control lever at the appropriate time. If the fire seems to be burning too quickly, turn the air down. If the fire is smoldering and there are no visible flames, turn the air up. This way you'll always be getting the most out of your fuel.

FUEL

All modern high efficiency fireplaces and woodstoves are designed to burn best with seasoned cordwood. Seasoned wood can be defined as wood that has been cut, split and let dry under cover for a minimum of 6 months, preferably a year or more. Dry seasoned wood generally contains less than 20% moisture content. Attempting to burn fuel with a high moisture content will be difficult and result in lower efficiency, increased creosote buildup and dark deposits on the glass. It's possible to burn a very large amount of wood and get very little heat if the wood is wet.

The type of wood you select is also important. All types of wood give off more or less the same number of BTU's per pound. Since softer woods are less dense than hardwoods it is possible to put more weight of hardwood in the firebox; in other words, all woodburning appliances will burn longer and more evenly with hardwoods. Never burn scrap, garbage, treated wood or driftwood as they produce much more pollution and can corrode the firebox and chimney as well. Burning large amounts of paper, cardboard, mill ends, or construction waste can easily over fire and damage the fireplace or even ignite a chimney fire if the flue is dirty.

FIRST FIRES

You will experience a slow start-up during the first few fires. The refractory bricks lining the firebox contain moisture from manufacturing and require a few hot fires to evaporate the moisture. While there is still moisture in the bricks, they will be black with smoke deposits. When the moisture has dissipated, the bricks will turn white. Unlike cast iron stoves, there is no need to cure the fireplace itself by starting with small fires and progressively larger ones. Feel free to light a large fire from the very start.

You will experience a slight odor during the first few fires. This odor comes from curing paint and oil burning off the metal. The odor may be strong enough to set off your smoke detector. Open the doors and windows to allow the room to properly ventilate.

LIGHTING

Ensure that the catalytic bypass is open (pulled all the way out) while starting a fire (see Figure 3). Leave it open until the fire is hot (approx. 15-30 minutes).

Ensure that the combustion air control lever is all the way to the right in the open position. You will want as much air as possible for the lighting process.

Start by laying your fire starter and kindling. Traditional fire starter is crumpled newspaper; make sure to use enough to light the kindling (5-6 pieces should do). Next lay the kindling crisscrossed over the newspaper. Using plenty of kindling ensures that the chimney will heat up quickly and establish a strong draft, **never use any flammable liquids**. Light the paper and close the door most of the way, but don't shut it completely. If the door is positioned correctly you will see air rushing into the fireplace, this will help the lighting process.

Once the kindling is lit and sustaining fire, you can add some small pieces of seasoned cordwood. Use the andirons in front to help position the cordwood so as not to flatten and smother the fire you've just created. Always add at least 3 pieces of cordwood. Position your cordwood in a manner that the fire will hit several pieces as it rises and has air gaps to flow through. Continue to leave the door slightly open until the cordwood is lit. Close the door completely when the fire is established, if the fire goes out you've shut the door too early.

❖ **WARNING: DO NOT USE A GRATE OR ELEVATE THE FIRE.**

❖ **WARNING: MAKE SURE TO KEEP THE FIRE BEHIND THE ANDIRONS. REPOSITION THE LOGS IF THEY FALL AGAINST THE GLASS.**

ENGAGE THE CATALYST

When the fire is hot, you should always engage the catalyst. To engage the catalyst, simply push the bypass handle all the way in so that the bypass damper is closed. Closing the bypass will force the smoke through the catalyst. When the catalyst is engaged you will receive more heat from your fireplace, and it will burn much more cleanly.

The catalyst should not be engaged (bypass closed) unless the fireplace is hot. If the bypass is closed before the fireplace is hot, the catalyst will get dirty and no extra heat will be generated. The catalyst must be at least 175°C (350°F) before it will start to burn off the wood smoke. Typically, this requires the fire to be lit for 15 to 30 minutes.

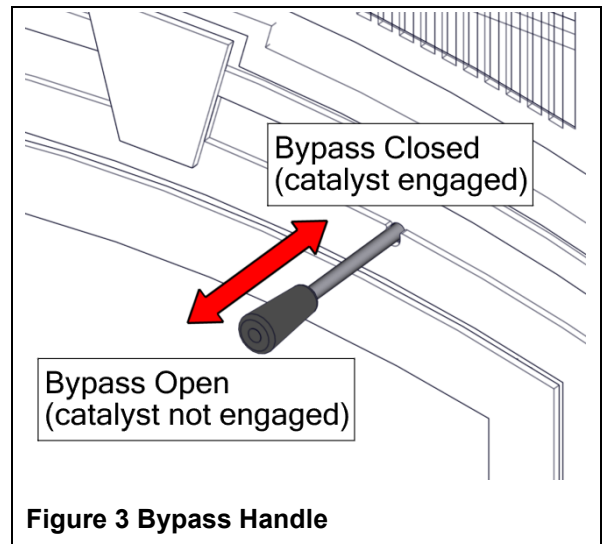

Figure 3 Bypass Handle

CATALYST TEMPERATURE PROBE

For an exact temperature reading at your catalyst, your fireplace is equipped with a temperature probe which measures the temperature within 1" of the catalyst. A wire and connector have been dropped down on the left side of the fireplace, inside the casing. You can connect to the probe with our optional Digital Temperature Display (FO-DTD) or any standard Type K Thermocouple/Sensor Thermometer.

For an accurate temperature reading the bypass must be closed. Here are the important temperature ranges that you need to be aware of:

- Below 175°C (350°F): not enough heat is generated from the fire, add more wood, open the air control and keep the bypass opened.
- Between 175°C (350°F) and 700°C (1300°F): the temperature is just right for the catalyst, add more wood as necessary and keep the bypass closed except for reloading.
- Above 700°C (1300°F): too much heat is generated from the fire, do not add more wood, close the air control and let the fire die down to allow the temperature to drop within the normal operating range.

Try to **AVOID OVERHEATING THE CATALYST** as much as possible. Every time you do so, you reduce its useful lifetime.

ADJUSTING THE BURN RATE

To get maximum efficiency out of your fireplace you will want to adjust the amount of combustion air entering the firebox at the appropriate times. Gauge how much to close the combustion air by how the fire reacts once the combustion air control lever has been moved. If the fire goes out and begins to smolder, there's too little combustion air entering the firebox. If there's no change to the burn pattern, you can continue to close the combustion air further. Eventually you should be able to close the combustion air all or most of the way. There should always be visible fire inside the firebox at every step of the process.

REFUELING

Have your next wood load ready when you open the door. The temperature of the catalyst will decrease dramatically while the door is open, so decreasing the amount of time the door is open will allow the catalyst to remain hot. Do not rush.

Pull the bypass handle all the way out, into the open position and turn off the central heat and internal blowers, if installed. The blowers may cause smoke to spill out of the fireplace if they are running.

The door should be opened slowly to keep smoke from spilling into your room. If you have a problem with smoke spillage, check to see that all kitchen and bathroom fans have been shut off. They can cause negative pressure in the house which pulls smoke out of the fireplace.

Take the time to poke and stir the unburnt wood that is left in the firebox. This will help revive the fire. Place the new logs in the firebox. Try to maintain a clear path in front of the pilot, which is the metal tube centered between the two andiron posts. The pilot brings an influx of air close to the coals that will help to keep the fire going. Once the new wood has been loaded, keep the door slightly ajar for about 3-10 minutes to get the fire going depending on how well seasoned your cordwood is and how much coals were left in the firebox. Once the new wood is well lit, close the door.

Close the bypass when the wood is well lit.

TROUBLESHOOTING PROBLEMS

If smoke comes into the house when the door is opened:

- You may have opened the door too quickly and created a suction of air into the room, this can be avoided by opening the door more slowly.
- Ensure your chimney is clean and your chimney cap is not plugged. Chimney caps with screens are more likely to become clogged with creosote buildup.
- Make sure you have adequate chimney height for your system. Refer to the Chimney section of this booklet and make sure to take altitude, and number of elbows into consideration.

- If you have purchased the central heat kit option or the circulating internal blower, make sure the blower is off before opening the door.
- Check to see if other fans in the home are running, particularly a kitchen range hood, or bathroom exhaust fan. This can affect the pressure in the home.
- Try opening a window near the fireplace a little, this will equalize the pressure in the home and should correct a draft problem. Once proper draft is established the window can be closed.
- Make sure you've used enough kindling to establish a hot fire quickly. The most likely time that smoke will enter the home is during the lighting process.
- If your fireplace burns excessively fast, seemingly uncontrollably:
- Check all door seals and gaskets to ensure that air is not leaking into the firebox. See "Door Seal" for details of how to verify the tightness fo the door.

MAINTENANCE

CATALYTIC COMBUSTOR

It is recommended to visually inspect combustor at least three times during the heating season. Over time ash can become attached to the catalyst. If ash is visible on the face of the catalyst, it should be removed when the catalyst is cold. Brush the catalyst with a soft bristle brush (e.g. paint brush) to clear the ash. Also pass a vacuum near the face of the catalyst to remove the remaining ash but try to avoid contacting the catalyst directly. Never touch the catalyst with any scrapers or hard bristle brushes and limit cleaning to the visible face of the catalyst. Attempting to clean the individual openings in the catalyst can do more harm than good.

If you notice that your fireplace is not creating as much heat as it once did, the catalyst may require cleaning or replacement. When having a hot fire with the bypass closed, watch the catalyst closely. If it is not burning red, then it is not firing. If the catalyst does not fire for several days, even during a hot fire, a replacement is required. The life expectancy of a catalyst is approximately 5-10 years. Replacement catalysts can be ordered from your local RSF retailer.

REPLACING THE CATALYST

When the catalyst requires replacement, a Catalyst Replacement Kit can be ordered from your local RSF retailer with the part code FO-CATP. To remove the old catalyst, start by removing the two bolts behind the notches in the heat shield at the top of the firebox with a 7/16" ratchet. Then remove the two bolts on either side of the catalyst. Remove the catalyst and the catalyst support plate. The gasket material that seals around the exterior of the catalyst will likely break and require replacement with the new gasket that is included with the FO-CATP.

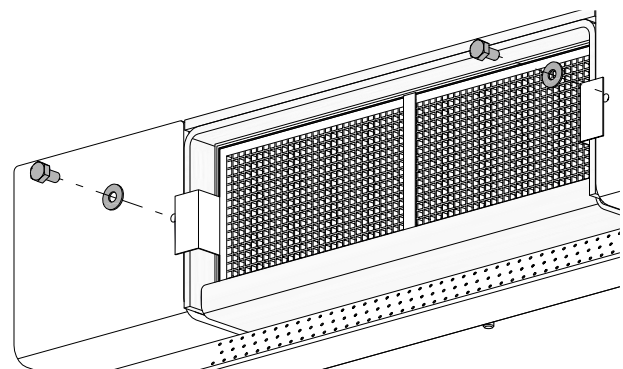
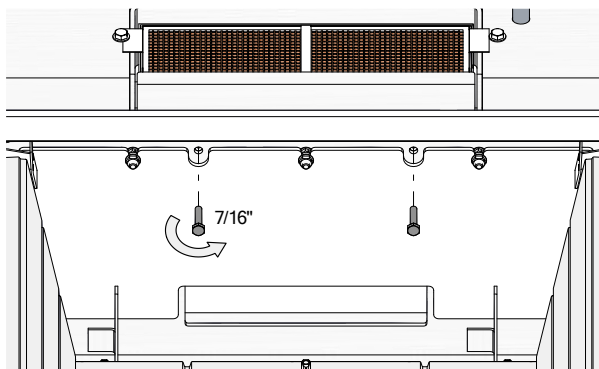

Wrap the new catalyst on all sides with the catalyst gasket. Enough gasket is supplied to wrap the catalyst with two layers of the gasket material. Carefully insert the catalyst and catalyst support plate into the opening and reinsert all four screws that hold it in place. The catalyst gasket expands as it is heated; so, it is normal for the gasket to have some small gaps after being inserted. As the gasket expands, the spaces will be filled.

CHIMNEY CLEANING

Check the chimney for creosote buildup every week or so until experience shows how often you need to clean it. A buildup of 1/8" (3mm) or more should be cleaned before more creosote accumulates. Close the fireplace door and open the bypass prior to sweeping. Use an 7" round brush.

Once the chimney has been swept, any creosote or ash that has fallen into the top of the fireplace can be removed with a flexible attachment for a vacuum (see Figure 4) through the bypass opening.

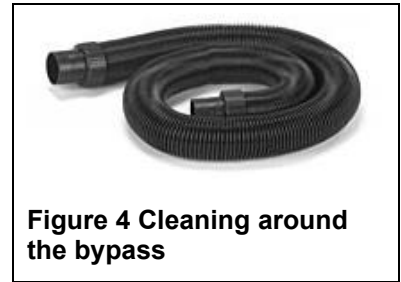

Figure 4 Cleaning around the bypass

DISPOSAL OF ASHES

Remove the ashes before they become too deep, i.e., before you have a spillage problem when you open the door.

The ashes should be placed in a metal container with a tight-fitting lid. The closed container of ashes should be placed on a non-combustible floor or on the ground, well away from all combustible materials pending final disposal. If the ashes are disposed of by burial, or otherwise locally dispersed, they should be retained in the closed container until all cinders have thoroughly cooled.

GENERAL CLEANING

The high heat paint and plating can be cleaned with a soft damp cloth. Use a mild detergent and water. Do not use abrasive cleaners.

PAINT

❖ **WARNING: AVOID SPRAYING CERAMIC GLASS CLEANER OR OTHER CLEANERS ON THE PAINT OF THE FIREPLACE. THEY MAY REMOVE THE PAINT AND MAKE TOUCHUPS DIFFICULT.**

You can touch up the face of the OPEL+ KEYSTONE with *Stove Bright* Metallic Black high temperature paint which is available at most fireplaces dealers. Follow the directions outlined on the spray can. **DO NOT** attempt to paint the fireplace while it is still warm. Keep the spray can away from any source of heat or open flame. Ensure that there is adequate ventilation in the room from the time you start painting until the paint is dry. *Stove Bright* is available in a wide range of colors if you want to change the color of your OPEL+ KEYSTONE.

We recommend that you take the time to protect or remove any item that you do not want to paint such as: the door glass, the plated door, the fireplace surroundings, etc. The glass can be removed from the door but you will have to replace the window gasket.

GLASS CLEANING

In a controlled combustion firebox, temperatures are not always high enough to keep the glass perfectly clean. A good hot fire once a day usually cleans off most of the deposits that have accumulated. Remember: the drier the wood and the hotter the fire, the cleaner the glass. A word of caution: although heat will not break the glass, impact can. Be careful not to hit the glass.

❖ **WARNING: NEVER CLEAN THE GLASS WITH AN ABRASIVE CLEANER. USE ONLY A CLEANER RECOMMENDED BY YOUR DEALER. NEVER CLEAN THE GLASS WHILE IT IS HOT, A SERIOUS BURN CAN RESULT. THERE ARE A NUMBER OF EXCELLENT WOOD STOVE GLASS CLEANERS AVAILABLE WHICH ARE FAR SUPERIOR TO REGULAR GLASS AND OVEN CLEANERS FOR WOOD STOVE APPLICATIONS.**

FACEPLATE REMOVAL

It should not be necessary to remove the faceplate of the OPEL+ KEYSTONE. If for some reason the faceplate of the fireplace must be removed, follow the steps below.

1. Open the fireplace door.

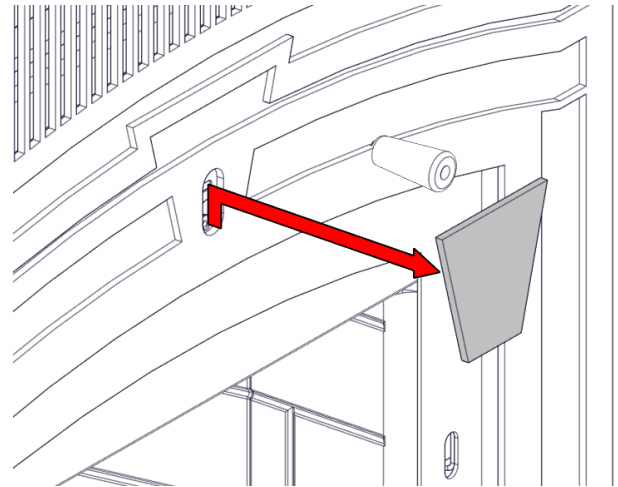
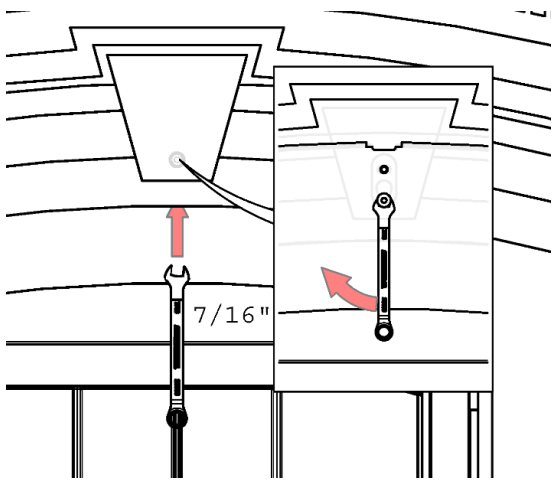

2. Remove the keystone centerpiece by loosening the nut on the back of the faceplate with a 7/16" wrench. It then must be lifted and then pulled forward.

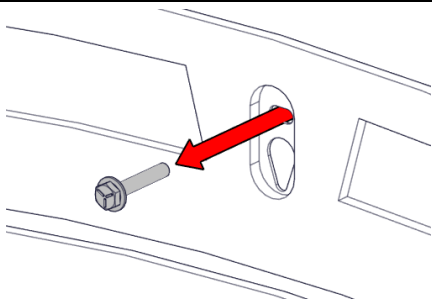

3. Remove the bolt behind the keystone.

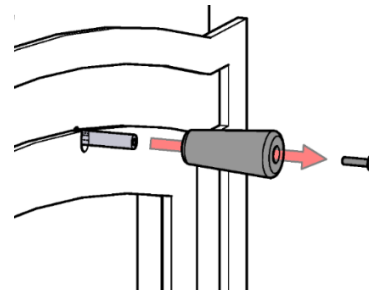

4. Remove the wooden handle on the catalytic bypass rod using a 5/32" hex key.

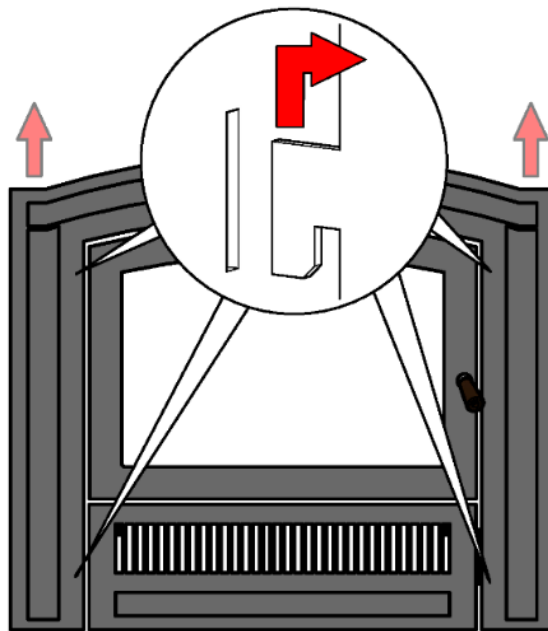

5. Grab the faceplate firmly and lift it off the fireplace. Four notches in the fireplace facing hold the Keystone faceplate in place. It must be lifted and then pulled forward.

DOOR SEAL

To check for a proper door seal, insert a thin sheet of paper between the door and the front of the fireplace and latch the door. Pull gently but firmly on the sheet of paper. If the paper either tears or is hard to retrieve, the adjustment is correct. Repeat this procedure along all sides of the door.

The most important factor for controlling the burning rate of the OPEL+ KEYSTONE is a good seal on the door gaskets. If the door gaskets are worn or damaged to the point where the seal is not adequate as described above, then remove and replace the gasket(s). Replacement kits are available from your RSF dealer.

The OPEL+ KEYSTONE Door cannot be adjusted to tighten the door seal. The gaskets must be replaced when necessary to resolve the issue.

♦ **NOTE:** An improper door seal can have a significant effect on the performance and durability of the fireplace. An air leak can result in reduced efficiency, over firing, excessive wood consumption and premature catalyst and fireplace failure.

DOOR ADJUSTMENT

For aesthetic reasons or to ensure the door handle properly aligns with the notch in the fireplace facing, the door hinges can be adjusted on the left side of the door.

The door can be adjusted left-right or slightly rotated against the front of the fireplace as follows (see Figure 5):

1. Open the door completely.
2. Using a 5/32" hex key (allen key), slightly loosen the screws holding the door hinge pins against the face of the fireplace. The hinge pins can be shifted left or right.
3. Verify the alignment of the door with the firebox opening and the latch opening.
4. Retighten the bolts once alignment is complete

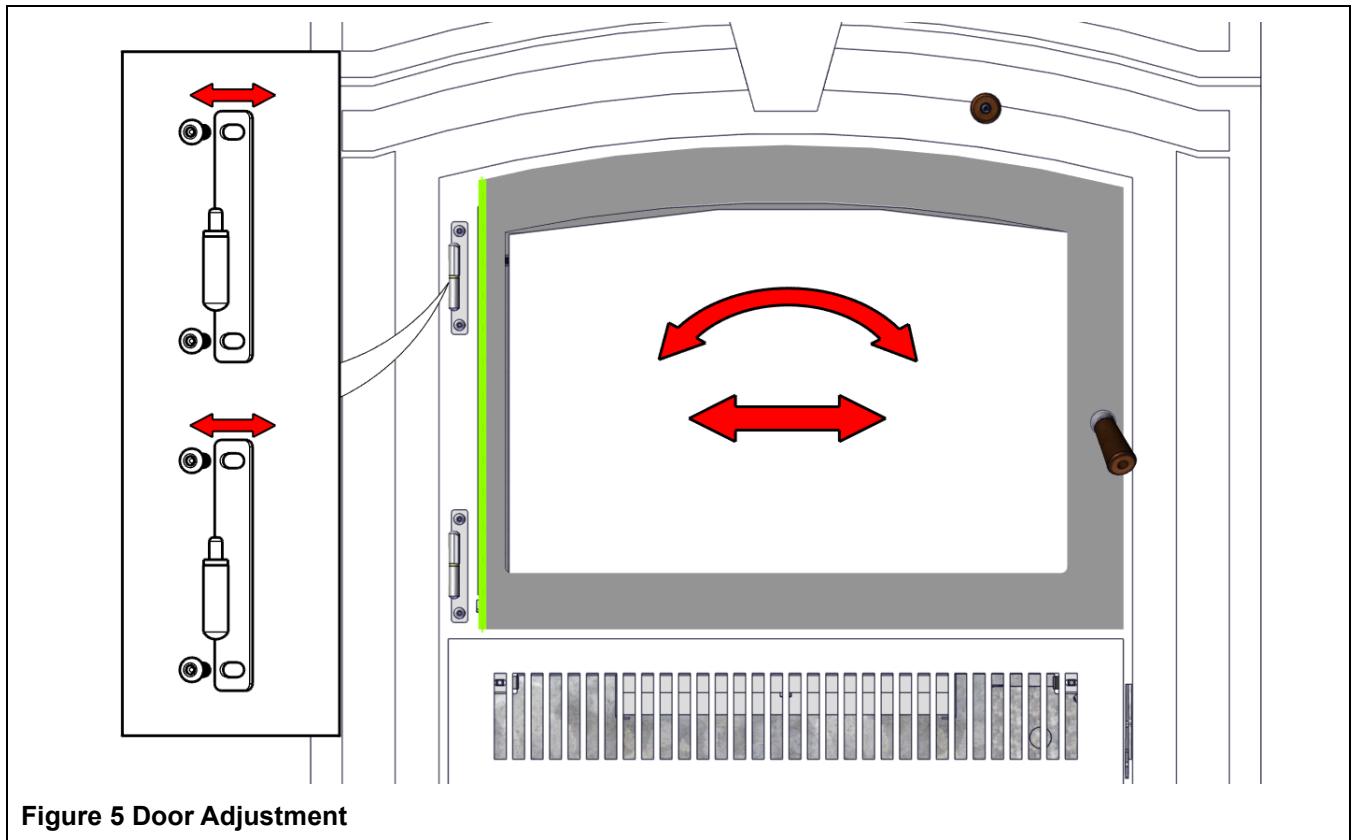

Figure 5 Door Adjustment

INSTALLATION

Check with your local authority having jurisdiction (such as municipal building department, fire department, fire prevention bureau, etc.) regarding restrictions and installation requirements, and the need to obtain a permit.

LOCATION

Your OPEL+ KEYSTONE fireplace may be installed in many different ways (see Figure 6) without any special floor reinforcement. We recommend that you take the time to plan your entire installation (fireplace, chimney, and options) before beginning the actual installation (refer to Figure 7 and Figure 8).

Dimensions of the fireplace along with clearances are shown in Figure 1 and Table 1.

❖ WARNING: IF THIS FIREPLACE IS NOT PROPERLY INSTALLED, A HOUSE FIRE CAN RESULT. FOR YOUR SAFETY, FOLLOW THE INSTALLATION INSTRUCTIONS AND CLEARANCES. DO NOT PACK REQUIRED AIR SPACES WITH INSULATION OR OTHER MATERIALS.

1. Note the location of roof and floor joists. Try to choose a location that does not require cutting them.
2. If possible, run the chimney up through the inside of the house. If it must be run outside, it should be enclosed in an insulated enclosure (see Installation: Chase Enclosure). Remember, a cold chimney causes poor draft.

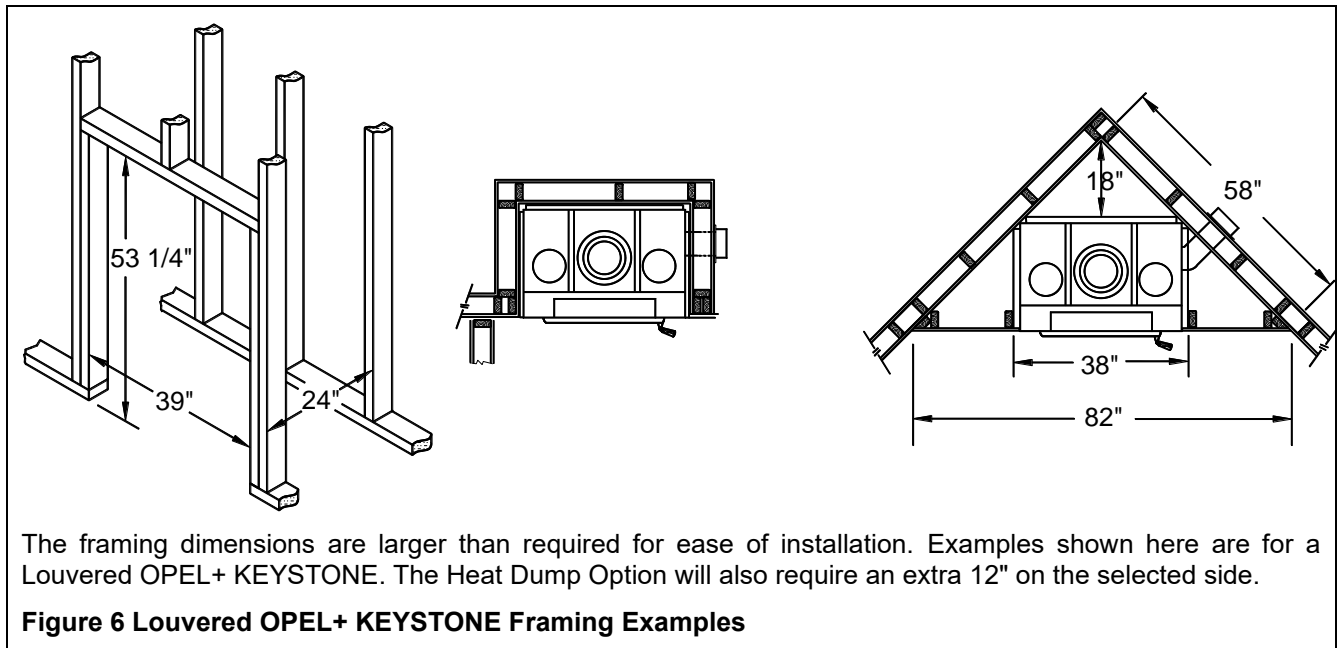

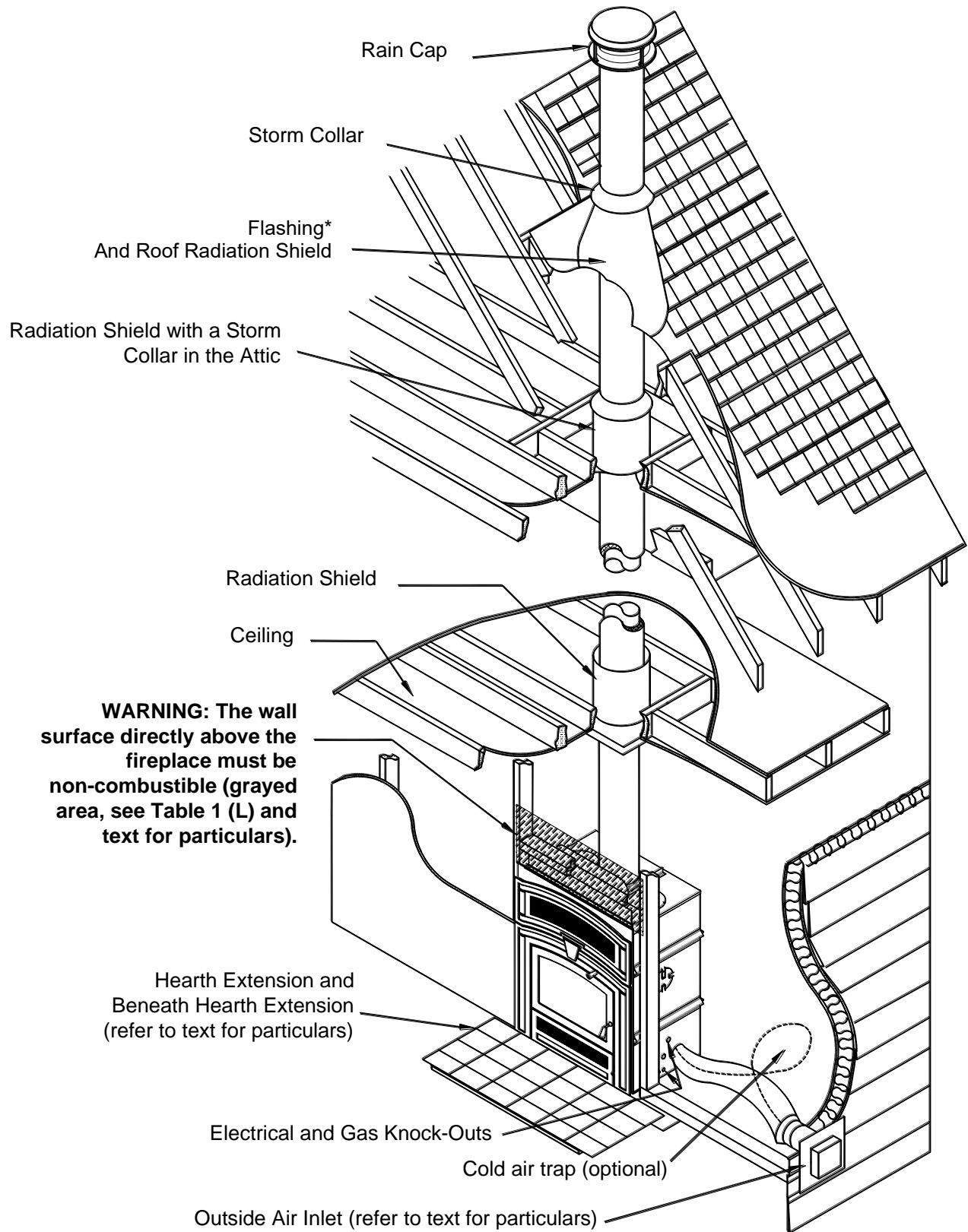

*Refer to text to determine appropriate flashing

Figure 7 Louvered OPEL+ KEYSTONE General Installation

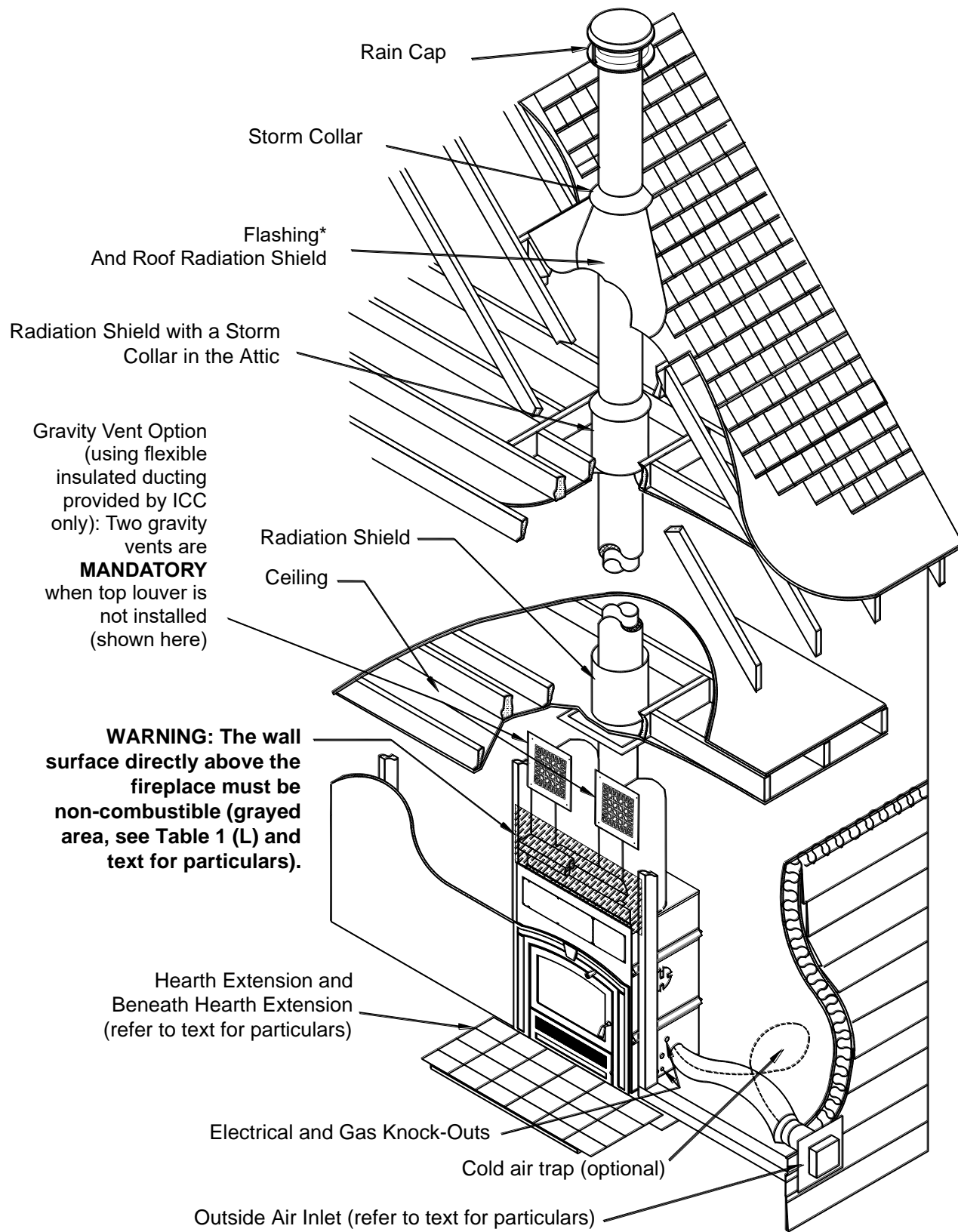

*Refer to the text to determine the appropriate flashing

Figure 8 OPEL+ KEYSTONE General Installation without the Top Louver

CEILING CLEARANCE

Ceiling clearance is the distance from the base of the fireplace to the ceiling. If you vent the fireplace enclosure, you can then have a lower ceiling clearance as specified in Table 1 (C) for a vented enclosure.

For a vented enclosure, you **MUST** install regular venting 3"x10" grilles or larger into holes cut within 1' of both the floor and the ceiling, to allow room air to circulate through the fireplace enclosure and reduce heat buildup. These venting grilles may be placed vertically or horizontally.

Under no circumstances should the distance between the ceiling firestop and the base fireplace be less than the dimension specified in Table 1 (C).

STANDOFFS INSTALLATION

Before you begin installing your fireplace, you **MUST** install the standoff provided on the top of the fireplace.

The back shield **MUST** be open on the back side as shown at the top of the Figure 9. You can then install the standoff on the fireplace as shown in Figure 9 with the screws provided in the manual bag.

DO NOT fill the gap between the fireplace and the standoff with insulation or any other material; it will be covered with the finishing material.

SECURING THE FIREPLACE IN PLACE

The fireplace **MUST** be attached to the floor.

Using the four small brackets that were securing the fireplace to the crate, attach the casing or base of the fireplace to the floor. Position the brackets all around the fireplace in the same fashion as they were on the crate. If possible, try to have at least one of the brackets screwed into the floor joist with 2" wood screws.

FRAMING

The enclosure walls can be framed with any suitable materials (2x4 or 2x6 studs, plywood, gypsum board, etc.). Because of the high heat output potential of the OPEL+ KEYSTONE, combustible materials must **NOT** go closer to the fireplace than the standoffs, top, back and sides.

❖ WARNING: COMBUSTIBLE FRAMING IS NOT PERMITTED IN THE SPACE DIRECTLY ABOVE THE FIREPLACE. THE ONLY EXCEPTION IS FOR FRAMING USED TO SUPPORT THE FACING MATERIAL AND MANTEL. THE AREA ABOVE THE FIREPLACE MUST BE FREE OF COMBUSTIBLES FOR AT LEAST THE HEIGHT PROVIDED IN TABLE 1 (C).

OUTSIDE AIR DUCT

After the fireplace is correctly positioned, connect the outside air inlet to the outside (see Figure 10).

Use an insulated aluminium flexible duct rated at over 200° F. The duct should not exceed 12' vertical rise above the base of the unit.

The air inlet should always be at least 5' lower than the chimney rain cap and must never terminate in attic spaces.

A 4" diameter duct can be used if the total duct run is less than 25'. For longer runs, use 5" diameter duct. Both 4" and 5" connecting sleeves are provided with the fireplace.

1. Find a convenient location for the combustion air duct and outside air inlet. The outside air inlet can be above or below floor level.

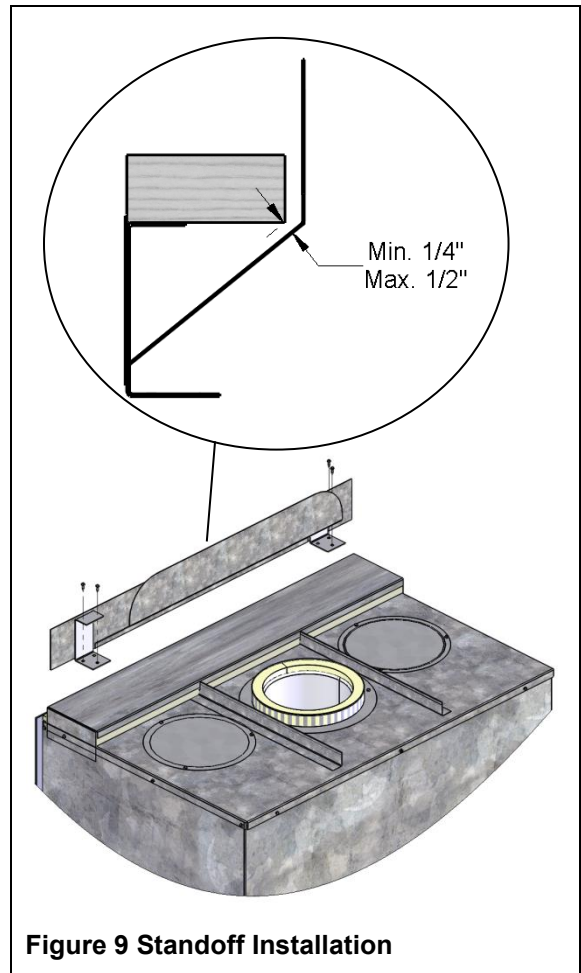

Figure 9 Standoff Installation

2. Make a 4 1/4" (5 1/4" if using a 5" diameter duct) hole in the outside wall of the house. Push the outside air inlet in from the outside. Seal the joint between the air inlet and the outside wall with an appropriate sealant.
3. Place the insulated flexible duct over the round sleeve on the outside air inlet. At both ends, carefully pull back the insulation and plastic cover, exposing the flexible duct. Then at each end, attach the duct with metal screws to the air inlet and to the fireplace connecting sleeve. Carefully push the insulation and cover back over the duct. Tape the plastic cover in place with 2" aluminium duct tape.

You can make a cold air trap by looping the outside air duct as shown in Figure 7 and Figure 8.

❖ CAUTION: WHEN RUNNING THE DUCT AROUND CORNERS, BE SURE TO PREVENT CRIMPING THE DUCT THAT WOULD RESTRICT THE COMBUSTION AIR FLOW.

CHIMNEY

This fireplace is certified for use with 7" ICC Model EXCEL chimney only. Please refer to Table 1 (D-E) for the minimum and maximum chimney height permitted with the OPEL+ KEYSTONE fireplace.

We recommend that the minimum height be increased by approximately 6" for every 1000' elevation above sea level. Every 15°, 30° or 45° offset (one pair of elbows) also increases the minimum height. See Table 3 for more precise recommended flue heights.

For example, if you are living 6015' above sea level, your chimney should terminate at least 15' from the top of the fireplace if it is a straight chimney or at least 18'6" if one 30° offset is used as shown in Table 3.

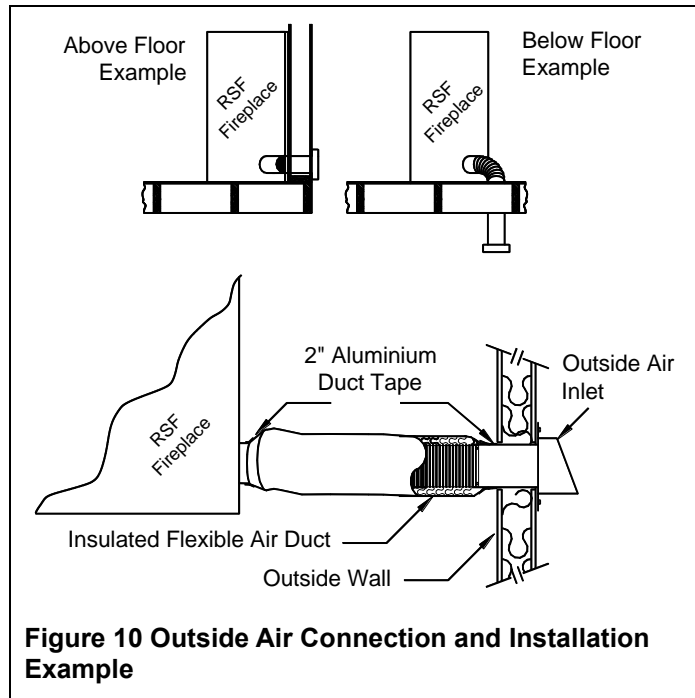

Figure 10 Outside Air Connection and Installation Example

Table 3 Minimum Recommended Flue Height

Elevation (ft)	Number Of Offset						
	Straight Chimney	1 x 15°	2 x 15°	1 x 30°	2 x 30°	1 x 45°	2 x 45°
0 - 1000	Minimum 12'	13'	14'	15'	18'	16'	20'
1001 - 2000	12'6"	13'6"	14'6"	15'6"	19'	16'6"	20'
2001 - 3000	13'	14'	15'	16'	19'6"	17'	21'6"
3001 - 4000	13'6"	14'6"	15'6"	17'	20'	18'	22'6"
4001 - 5000	14'	15'	16'	17'6"	21'	18'6"	23'
5001 - 6000	14'6"	15'6"	17'	18'	21'6"	19'	24'
6001 - 7000	15'	16'	17'6"	18'6"	22'	20'	24'6"
7001 - 8000	15'6"	16'6"	18'	19'	23'	20'6"	25'6"
8001 - 9000	16'	17'	18'6"	20'	24'	21'	26'6"
9001 - 10000	16'6"	17'6"	19'	20'6"	24'6"	22'	27'

Flue height is measured from the top of the fireplace to the top of the chimney before installing the rain cap.

If you have two different offsets (two pairs of different elbows), simply use the column for two offsets of the biggest pair of elbows at your elevation to get your Minimum Flue Height.

CHIMNEY INSTALLATION

Make sure to read the EXCEL Chimney installation manual concerning requirements for supports, bracing, anchors, etc. The EXCEL Chimney manual is available at you RSF dealer or on our web site: www.icc-rsf.com. Refer to Table 1 (F) for the maximum chimney height that can be supported by the top of the fireplace.

❖ **WARNING: THE CLEARANCE BETWEEN THE CHIMNEY AND COMBUSTIBLE MATERIAL MUST BE 2" OR MORE. DO NOT FILL THIS AREA WITH INSULATION.**

1. Cut and frame the required holes in the floor(s), ceiling(s) and roof where the chimney will pass through. The rough opening in the framing is 13" square (the opening can be slightly bigger, up to 13 1/2", but NEVER smaller).
2. From below, install a radiation shield in each floor through which the chimney passes. At the attic level, install a radiation shield and a storm collar as shown in Figure 11.

❖ **WARNING: A RADIATION SHIELD MUST BE INSTALLED AT EACH FLOOR WHERE THE CHIMNEY PASSES THROUGH.**

3. Remove the flue adapter from the fireplace, put the screws aside. Install the flue adapter on the first chimney length and secure it with the screws provided. Reinstall the flue adapter on the fireplace and secure it with the screws you have put aside earlier. Assemble the rest of the chimney.

The chimney must extend at least 3' above its point of contact with the roof and at least 2' higher than any wall, roof, or building within 10' of it. If the chimney is higher than 5' above the roof, it must be secured using a roof brace.

4. At the roof, install a roof radiation shield (XM-7ERRS). The roof radiation shield must be installed so it extends 1" above the roof line.
5. Put the roof flashing into place.
 - If the chimney is enclosed to the roof: use a vented flashing .
 - If the chimney is not enclosed to the roof: use a regular flashing.
6. Seal the joint between the roof and the flashing with roofing tar. For sloping roofs, place the flashing under the upper shingles and on top of the lower shingles. Nail the flashing to the roof using roofing nails.
7. Place the storm collar over the chimney and flashing. Seal it around the chimney with silicone sealer (**DO NOT use roofing tar**).
8. Fit the rain cap on the chimney. Secure it tightly in place.

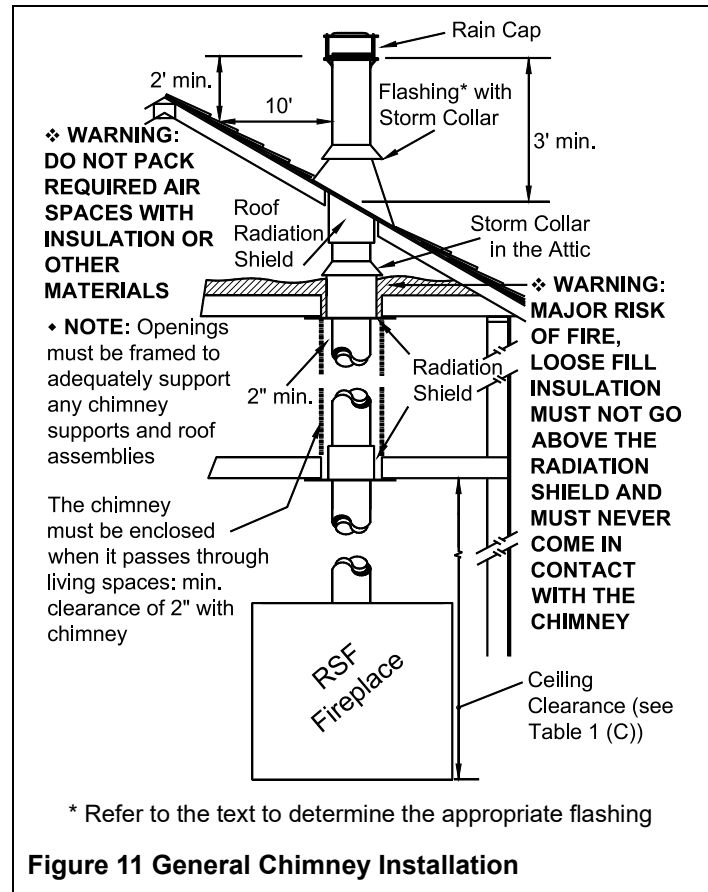

OFFSET CHIMNEY

An elbow may be installed directly on top of the fireplace if required. See the detailed offset charts in the EXCEL chimney installation manual. Use the offset option if you need to clear a joist or pass around a cupboard. See Figure 12 and Figure 13 for examples.

- Maximum offset angle:
 - In **USA**: 30°;
 - In **Canada**: 45°.
- Maximum number of elbows: four, resulting in two offsets and returns.

Install the fireplace and chimney as described earlier. When you require an elbow, proceed as follows:

1. Install the required elbow. Turn it in the desired direction, and fasten it to the other section with 3 metal screws at the joints.
2. Install enough lengths to obtain the desired offset. Secure each joint with 3 metal screws.
3. Use another elbow to return the chimney to the vertical direction.
4. Install a wall support, or an offset support above each offset to support the weight of the chimney (elbows are not designed to support the chimney above an offset).

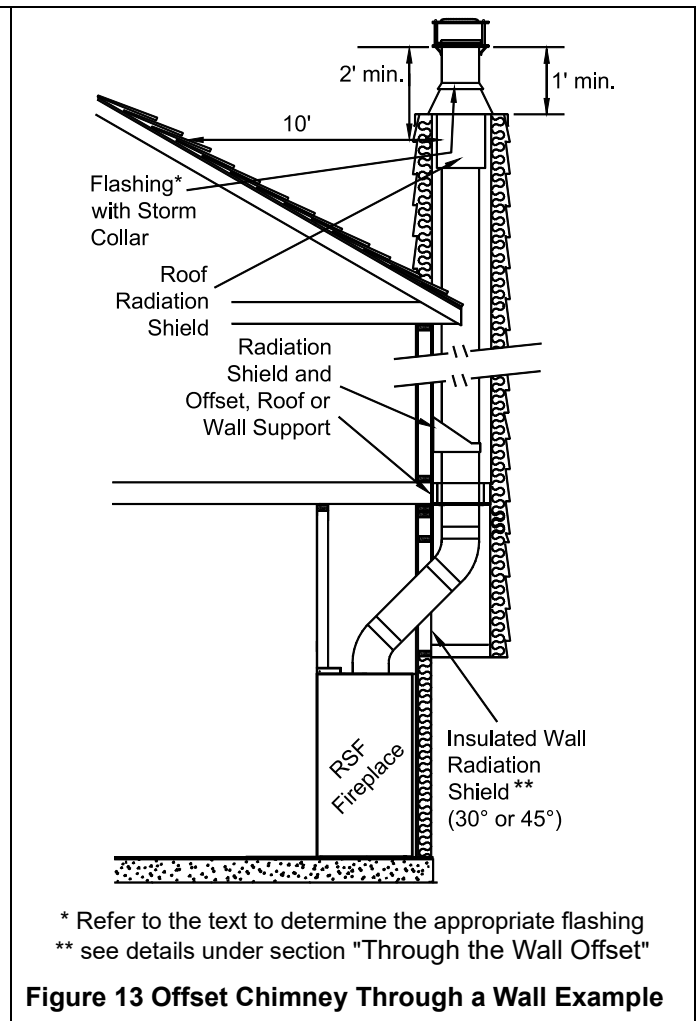
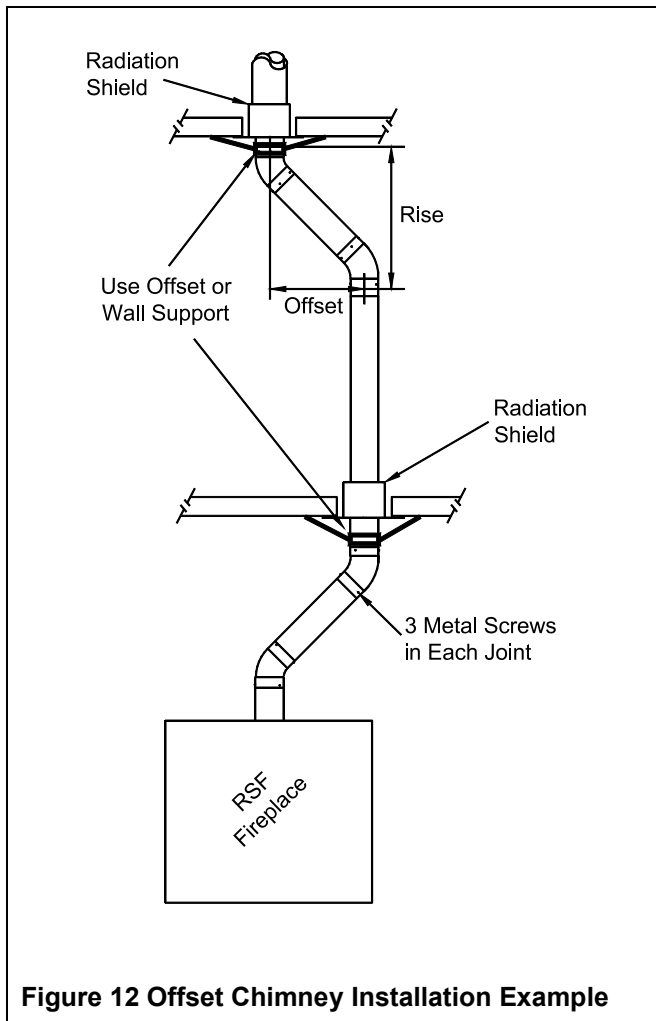

Through the Wall Offset

You can also go through the wall at an angle starting directly at the fireplace as depicted in Figure 13. An angled wall insulated radiation shield (XM-7EWRSI30 or XM-7EWRSI45) must be used wherever the chimney passed

through an exterior wall. Make sure you have enough ceiling height. If not, you might want to consider installing the fireplace in an outside chase.

If the chimney is enclosed once outside of the house, do not install the outside plate of the angled wall insulated radiation shield.

Refer to the angled wall insulated radiation shield installation sheets for more detailed installations instructions.

CHASE ENCLOSURE

If the chimney runs up the outside of the house, we recommend that it be enclosed in a chase structure. The chase should be constructed in such a way that it is an extension of the home (see Figure 14). It should be well insulated between the footings and the floor of the home to prevent heat loss. If the climate in your area is mild, insulate the chase at least to the first firestop. If the climate in your area is very cold, insulate the chase to the top to keep the chimney warmer, increase the draft, and reduce creosote buildup. We also recommend to insulate the ceiling of the chase just as if it were in the attic space. This will prevent cold air from dropping down through the chase and into the room where the fireplace is installed (see Figure 14).

Some local codes require that the walls be insulated, vapor sealed and sheathed with a fire rated gypsum board (see Figure 14). We strongly recommend this procedure for all installations to prevent cold drafts from originating in the fireplace enclosure. If you follow this procedure, we recommend that you do not insulate the wall above the front of the fireplace.

♦ **REMEMBER:** Check local codes concerning installation requirements and restrictions in your area.

MASONRY CHIMNEY

Installing your OPEL+ KEYSTONE fireplace with a masonry chimney still requires using EXCEL chimney from the top of the fireplace to the wall where it will connect to a listed liner that will run up inside the masonry chimney (see Figure 15).

The stainless-steel liner should be fitted inside the clay liner all the way to the top of the masonry chimney. It is not meant to replace the clay liner. You can use either the EXCEL liner or any other listed liner to ULC-S635, ULC-S640 or UL-1777.

Special care is to be taken to make sure that you have a good solid connection between the EXCEL chimney and the liner. A masonry adaptor (FO-FDM7) was designed specifically for that purpose and is available from your RSF dealer. It will attach to the liner with 3 stainless steel rivets (provided) and to the EXCEL chimney with 3 screws (provided).

After mortaring in place, the connection between the EXCEL chimney and the liner should not be visible in order to isolate the heat released through the liner from the fireplace enclosure.

As depicted in Figure 15, you must install at least one 18" length of EXCEL chimney after the EXCEL chimney elbow. The uppermost part of the EXCEL chimney - where it enters the masonry chimney - must be a minimum of 12" from the ceiling.

♦ **NOTE:** If the ceiling is high enough, you can install one or more EXCEL chimney lengths directly on the fireplace before the elbow.

If you use a flexible liner, make sure to be careful when cleaning to ensure that the stainless-steel flexible liner is not dislodged in any way.

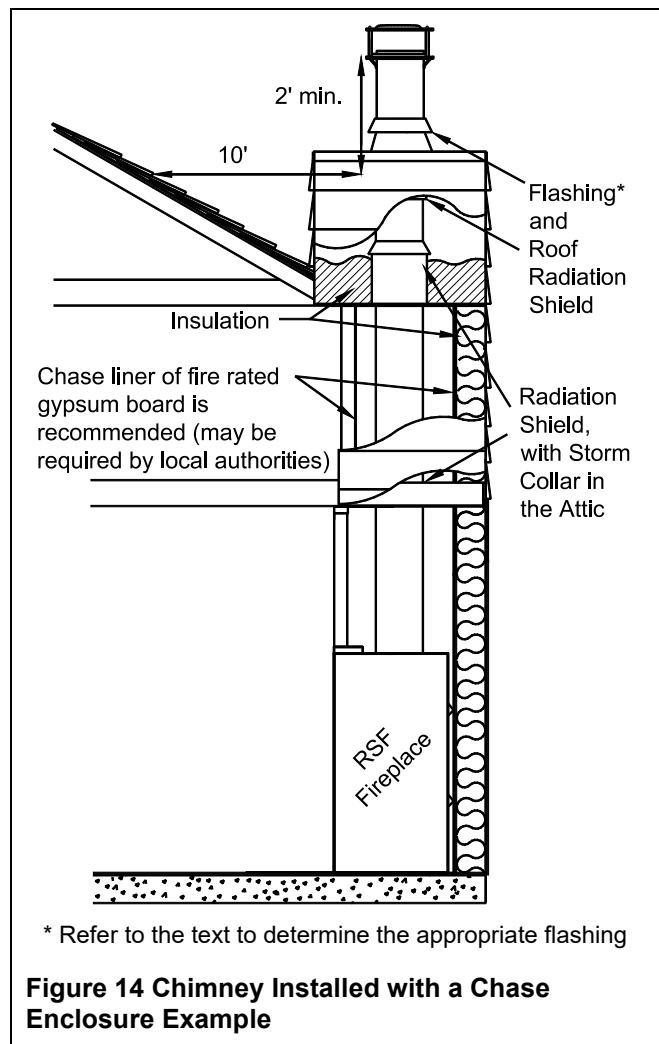

Figure 14 Chimney Installed with a Chase Enclosure Example

Using an Existing Masonry Chimney

❖ **WARNING: IF YOU ARE CONSIDERING USING AN EXISTING CHIMNEY, IT MUST FIRST BE THOROUGHLY INSPECTED BY AN AUTHORITY HAVING JURISDICTION TO DETERMINE THE FOLLOWING:**

1. The masonry chimney is well constructed and fully lined, in accordance with Local Building Codes and the National Building Code of Canada (NBC) or National Fire Protection Association chimney standard (NFPA 211).
2. It has been thoroughly cleaned of any soot or creosote residue and inspected to determine that it is in good working condition.
3. There is no insulation of any type in contact with the masonry chimney and there is no insulation stuffed anywhere in the chimney.
4. All the necessary clearances around the masonry chimney, along the complete run of the chimney, are respected as per NBC or NFPA 211. If the masonry chimney is enclosed in drywall, openings will probably be required in order to verify clearances at all points.
5. The masonry chimney will only be used for the fireplace and no other appliance.

If major repairs are required to meet the above conditions, a new chimney should be constructed.

To make the hole through the masonry chimney and make the connection to the fireplace, we recommend that you follow these steps:

1. Sight-in and mark the outline of where the EXCEL chimney will penetrate the masonry chimney.
2. Using a large ($\frac{3}{4}$ " - 2") masonry drill bit, drill a hole exactly in the center of the oval outline. With a masonry hammer and drill, slowly enlarge the hole to the size required. Remember to work from the center out. Be especially careful with the clay liner behind the brick because three sides of it must stay in place.
3. Bring the stainless-steel liner down from the top of the chimney.

If you are using a rigid liner you will need enough room to secure an elbow to it with at least two screws.

If it is difficult to install rigid stainless-steel liner in the existing masonry chimney or for a masonry chimney with less than 10"x10" inside, a listed stainless steel flexible liner can be used along with a flexible/rigid adaptor (LM-7LAF) available from your RSF dealer.

4. Install the liner elbow and masonry adaptor on the lower end of the liner.
5. Move the fireplace forward enough to install the EXCEL chimney on the fireplace (elbow and length) then move the fireplace back into position as you connect the masonry adaptor to the EXCEL chimney.

Using a New Masonry chimney

Since the masonry chimney is not build yet, we recommend that you position your fireplace, install the EXCEL chimney on it and connect to the first length of liner before building the chimney as explained above and shown in Figure 15 . The liner sections can easily be installed as the layers of brick are being placed. Since this is a new chimney, we recommend that you build it to the right size, so you do not have to ovalize the liner but if you choose to use a 6"x10" clay liner you will need to ovalize the stainless-steel liner to fit into the clay liner.

♦ **Remember:** The stainless-steel liner should be fitted inside the clay liner all the way to the top of the masonry chimney. It is not meant to replace the clay liner.

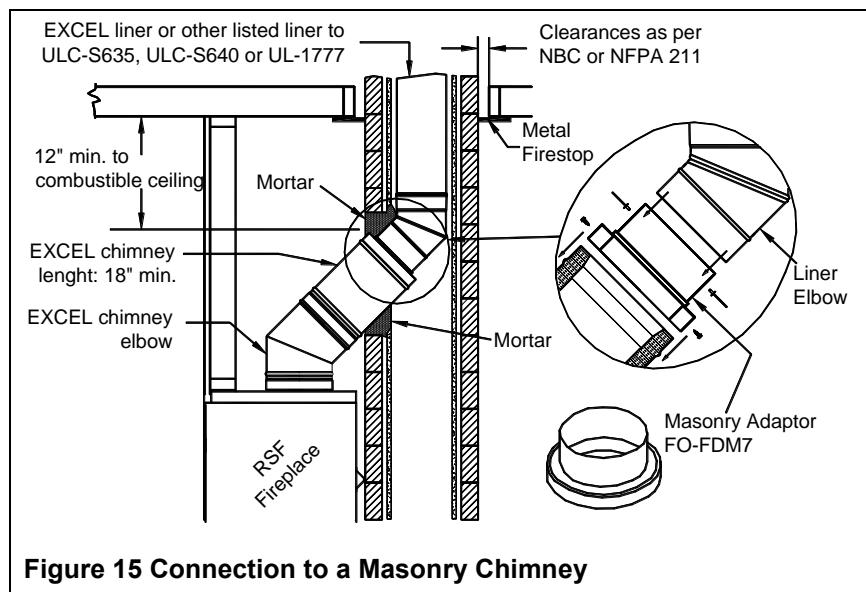

Figure 15 Connection to a Masonry Chimney

FINISHING AROUND THE FIREPLACE

Finishing materials that cover the facing of the fireplace MUST BE NON-COMBUSTIBLE (e.g. brick, slate, ceramic tile, etc.). Gypsum board is NOT an acceptable facing material. Gypsum boards cannot get closer to the fireplace than the side standoffs and the top clearance specified in Table 1 (L) and shown in Figure 7 and Figure 8.

❖ **WARNING: MAKE SURE TO RESPECT THE TOP CLEARANCE SPECIFIED IN TABLE 1 (L).**

MANDATORY OPTIONS WITH TOP LOUVER BLOCKED

If you are planning to cover the top louver opening with stone, you MUST install the Louver Blocking Plate (provided) and TWO Gravity Vent Kits (sold separately, see the "

Gravity vent Options" to select the kit of your choice) to provide an evacuation path for the heat. Neglecting to install both gravity vent kits will result in overheating of the unit and may put your safety at risk. Refer to each option's installation instructions for details

Use only genuine RSF parts. The use of any substitutes will decertify the system and may put your safety at risk.

HEARTH EXTENSION

The area immediately in front of the fireplace must be protected by a non-combustible material such as brick, tile, stone, or slate. Refer to Table 1 (G-H) for the depth and width that the hearth protection should extend beyond the front and both sides of the door opening (see Figure 1). There is no minimum thickness required for the hearth extension.

BENEATH HEARTH EXTENSION

If the OPEL+ KEYSTONE is installed on a non-combustible floor, the spark guard specified below is not required.

Install the spark guard provided (5" x 36" piece of sheet metal) halfway under the fireplace and halfway under the hearth extension and centered on the door opening. The spark guard will extend 2½" beneath the fireplace. This will make certain that sparks cannot lodge in this area and start a fire. If necessary, the provided spark guard can be cut to the minimum width specified in Table 1 (I).

If you are preparing a raised installation, you will need a custom-made spark guard, either a "Z" shaped spark guard or a right-angle spark guard (see Figure 17). The Z-shaped spark guard must be used if the height between the bottom of the fireplace and the top of the non-combustible flooring of the hearth extension is less than or equal to 2½". The height of the Z-shaped spark guard must equal the distance between the floor and the base of the unit and go under the hearth extension and the fireplace by at least 2½". If the unit is installed higher than 2½" from the top of the flooring, a right-angle spark guard is necessary. The sides of the right-angle spark guard should be at least 2½" x 2½" and must be covered with non-combustible material. Any custom-made spark guard must have the minimum width specified in Table 1 (I) and be installed centered on the door opening.

◆ **NOTE:** Custom-made spark guards are not supplied.

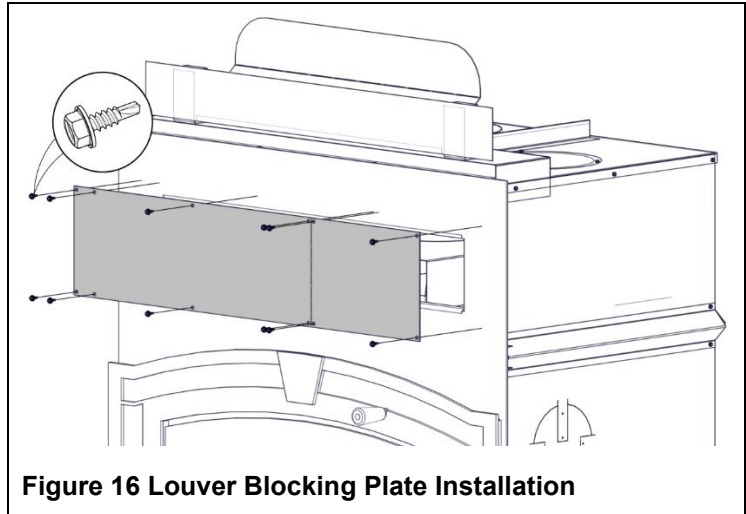

Figure 16 Louver Blocking Plate Installation

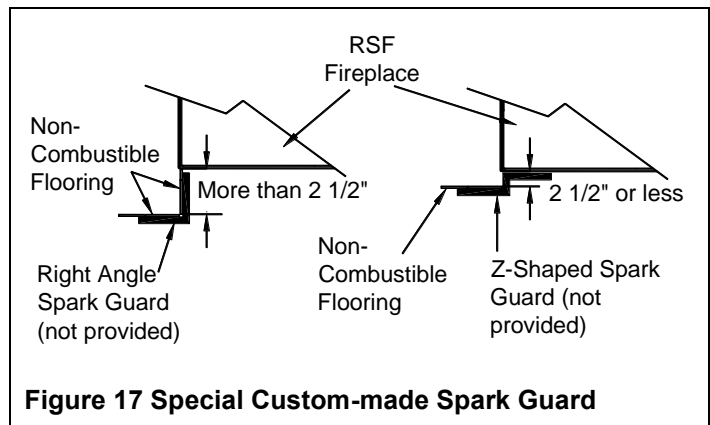

Figure 17 Special Custom-made Spark Guard

MANTEL

Masonry and other non-combustible mantels (shelf and posts) can be placed anywhere on and around the fireplace facing, without blocking any of the bottom and top louvers unless you install the appropriate options (see the "Mandatory Options with Top louver blocked" section).

For combustible mantel shelves, please see Table 1 (J-K) for the maximum depth and its installation clearance requirements. See Figure 1 for an example.

Vertical mantel posts on the sides of the fireplace opening must be non-combustible. Combustible mantel posts are not permitted unless they meet the clearance required to a perpendicular sidewall (see Table 1 (B)).

The only combustible material accepted below the minimum clearance for combustible materials above the fireplace (see Table 1 (L)) is for a mantel shelf.

REFRACTORY BRICKS' INSTALLATION

The refractory bricks come pre-installed. These instructions show the order for the refractory bricks' installation. For removal, simply follow these instructions in the reverse order, see Figure 18.

Small cracks and wear in the refractory bricks do not require refractory bricks replacement. Replacement need only happen when the refractory bricks have missing pieces (chunks) or when the metal of the firebox is visible through the bricks.

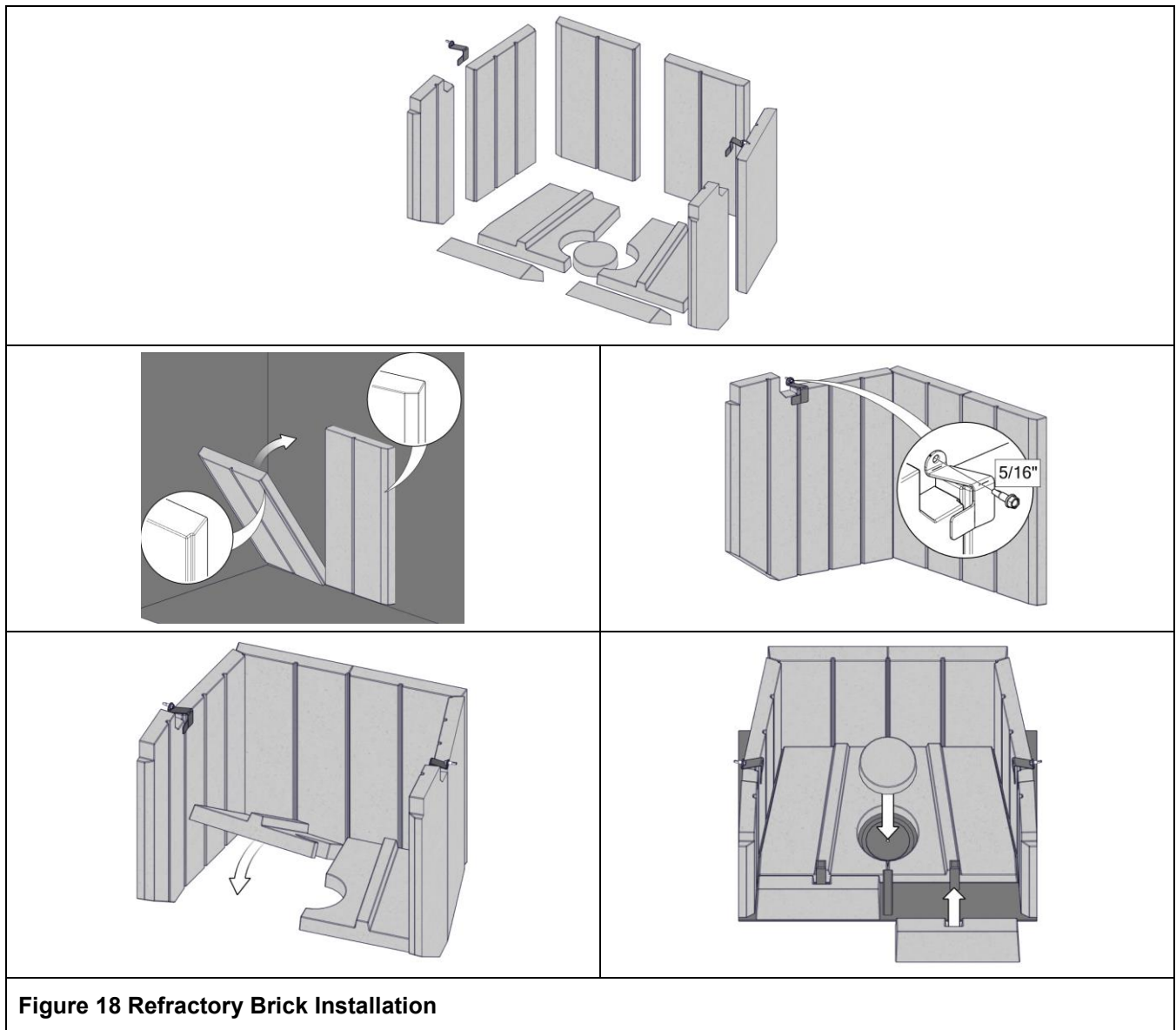

Figure 18 Refractory Brick Installation

GAS LOG INSTALLATION

The OPEL+ KEYSTONE can be converted into a gas fireplace as long as you keep the combustion air control lever all the way open (towards the right) and keep the bypass open at all times, and make the modifications to the fireplace as explained below. This is to allow enough air for an adequate and safe operation of the gas log. You can use any gas log set up to a maximum of 35,000 BTU that is listed to ANSI Z21.60/CSA 2.26.

❖ WARNING: THIS FIREPLACE HAS NOT BEEN TESTED WITH AN UNVENTED GAS LOG SET. TO REDUCE RISK OF FIRE OR INJURY, DO NOT INSTALL AN UNVENTED GAS LOG SET INTO THIS FIREPLACE.

Remember that the installation of the gas line should be done by qualified personnel. All gas installations should be in accordance with local ordinances and the appropriate Gas Code.

We do not require any minimum clearances between the side or the top of the firebox and the gas log set. However, any clearances stated by the gas log set manufacturer must be maintained. You may install the gas valve inside the firebox if the gas log set manufacturer allows this in its installation instructions, and if the required clearances are met.

To convert the OPEL+ KEYSTONE please carefully follow the following steps:

1. There is a 1 ½" hole on both sides of the fireplace, about 9" up from the bottom of the fireplace. The gas line must come into the fireplace through one of these holes. Choose the side of installation that is more convenient to you.
2. There are a few parts that you need to remove from the OPEL+ KEYSTONE to be able to accommodate a gas firelog. Make sure to store them for safekeeping, you will need to reinstall them all if you ever intend to burn wood again in your OPEL+ KEYSTONE:
 - Remove the round central refractory brick.
 - Remove the two bottom refractory brick from the firebox.
 - Open the bottom louver and remove the nut and bolt on the central plug of the firebox. The nut is a locknut so you will need to hold it tightly to unscrew the bolt. Remove the top and bottom plates, the nut and the bolt.
3. Remove the side firebrick on the side that you have decided to bring the gas into the fireplace, you will need to drill a hole from the outer side of the fireplace through the side of the firebox.
4. Then you will need to drill or break a hole through the side firebrick to allow the gas line through once you put the firebrick back in place.
5. Make sure to leave the ash pan hole completely open, this will bring air to the gas log.
6. Proceed with the installation of the gas log as per the gas log manufacturer installation instructions. Make sure to carefully read and follow the gas log installation instructions. Make sure also to respect all clearances stated by the gas log manufacturer.

❖ WARNING: THE MAXIMUM GAS OUTPUT ALLOWED IN THE OPEL+ KEYSTONE IS 35,000 BTU. THE GAS LOG HAS TO BE LISTED TO ANSI Z21.60/CSA 2.26. THE COMBUSTION AIR CONTROL MUST BE FULLY OPEN WHEN THE GAS LOG IS FUNCTIONING.

When operating an OPEL+ KEYSTONE with a gas log installed, make sure to follow the gas log manufacturer operating instructions.

LISTING LABEL

The listing label is glued to the bottom of the fireplace. Just remove the bottom louver, the listing label is below the floor shield.

DO NOT REMOVE THIS LABEL

U.S. ENVIRONMENTAL PROTECTION AGENCY CERTIFIED TO COMPLY WITH 2020 PARTICULATE EMISSION STANDARDS USING CRIB WOOD.

TESTED TO:
UL 1277 CANULC-3610 / CANULC-S027
EPA 2020 CRIB WOOD, CERTIFIED AT 0.7 GH

INSTALL AND USE ONLY IN ACCORDANCE WITH THE MANUFACTURER'S INSTALLATION AND OPERATING INSTRUCTIONS. **DO NOT OBSTRUCT COMBUSTION AIR INLET.** DO NOT USE A FIREPLACE INSERT OR OTHER PRODUCTS NOT SPECIFIED FOR USE IN THIS PRODUCT. OPERATE WITH DOOR(S) FULLY OPEN OR FULLY CLOSED. OPEN BYPASS BEFORE OPENING THE DOOR(S).

MINIMUM CLEARANCES TO COMBUSTIBLE MATERIALS	
SIDEWALL	18 IN. (408 mm) FROM FIREBOX OPENING.
HEIGHT OF MANTEL SHELF: MAX. 12 IN. (305 mm) DEEP	36 1/2 IN. (927 mm) FROM FIREBOX OPENING
UNIT BACK, SIDES AND BOTTOM	0 IN. (0 mm) TO SPACERS

* SEE INSTALLATION INSTRUCTIONS FOR OTHER MANTEL HEIGHTS VS DEPTHS. COMBUSTIBLE MATERIALS ARE NOT PERMITTED ON FACE OF UNIT. NON-COMBUSTIBLE HEARTH EXTENSION MUST BE 18 IN. (457 mm) DEEP BY 42 IN. (1070 mm) WIDE, AS SPECIFIED IN THE INSTALLATION MANUAL.

COMPONENTS REQUIRED FOR INSTALLATION:

- USE 4 IN. OR 5 IN. (102 OR 127 mm) DIAMETER FLEXIBLE DUCT AND COMBUSTION AIR INLET ASSEMBLY.
- USE THE ICC MODEL 7 IN. (178 mm) EXCEL CHIMNEY AND LISTED COMPONENTS AS PER INSTALLATION INSTRUCTIONS.

REFER TO MANUFACTURER'S INSTALLATION AND OPERATING INSTRUCTIONS FOR OPTIONAL COMPONENTS: RAIN, GRAVITY VENT SYSTEM AND CENTRAL HEATING ACCESSORIES. ONLY ORIGINAL RSF OPTIONS SHOULD BE USED WITH THIS FIREPLACE, AND PURCHASED THROUGH RSF DEALERS.

WARNING: THIS FIREPLACE HAS NOT BEEN TESTED WITH AN UNVENTED GAS LOG SET. TO REDUCE RISK OF FIRE OR INJURY, DO NOT INSTALL AN UNVENTED GAS LOG SET INTO THE FIREPLACE.

REPLACE GLASS ONLY WITH 5 mm CERAMIC GLASS. OPERATE ONLY WITH FIREBRICK IN PLACE. FOR USE WITH SOLID WOOD FUEL ONLY. DO NOT OVERFIRE UNIT.

THIS WOOD HEATER CONTAINS A CATALYTIC COMBUSTOR, WHICH NEEDS INSPECTION AND REPLACEMENT FOR PROPER OPERATION. CONSULT THE OWNER'S MANUAL FOR FURTHER INFORMATION. IT IS AGAINST FEDERAL REGULATIONS TO OPERATE THIS WOOD HEATER IN A MANNER INCONSISTENT WITH THE OPERATING INSTRUCTIONS IN THE OWNER'S MANUAL, OR IF THE CATALYTIC ELEMENT IS DEACTIVATED OR REMOVED.

THIS WOOD HEATER IS NOT APPROVED FOR USE WITH A FLUE DAMPER OTHER THAN AN OPEN-CLOSE FLUE DAMPER.

NE PAS ENLEVER CETTE ÉTIQUETTE

CERTIFIÉ CONFORME PAR EPA (É.-U.) AUX NORMES 2020 D'ÉMISSION DE PARTICULES EN UTILISANT UNE CHARGE NORMALISÉE.

MODELE: OPEL+2C / OPEL+3C / OPEL+4C / OPEL+ KEYSTONE

MIS À L'ESSAI SELON LES NORMES UL 1277 CANULC-3610 / CANULC-S027

CERTIFIÉ EPA 2020, CHARGE NORMALISÉE, À 0,7 GH

INSTALLER ET UTILISER SELON LES INSTRUCTIONS D'INSTALLATION ET DE FONCTIONNEMENT DU MANUFACTURIER. **NE PAS OBSTRUER L'ENTRÉE D'AIR COMBUSTIBLE.** N'UTILISEZ PAS D'ENCASTRABLE OU AUTRES PRODUITS NON SPÉCIFIÉS POUR UTILISATION AVEC CE PRODUIT. FAIRE FONCTIONNER LE FOYER AVEC LA (LES) PORTE(S) COMPLÈTEMENT OUVERTE(S) OU FERMÉE(S). OUVRIER LE REGISTRE DE DÉRIVATION AVANT D'OUVRIR LA (LES) PORTE(S).

DÉGAGEMENTS MINIMAUX AUX MATÉRIELS COMBUSTIBLES	
MUR DE CÔTÉ	18 PO. (408 mm) DE L'OUVERTURE DE LA BÔTE À FEU
HAUTEUR DE LA TABLETTE DE MANTEAU DE CHEMINÉE: MAX. 12 PO. (305 mm) DE PROFONDEUR	36 1/2 PO. (927 mm) DE L'OUVERTURE DE LA BÔTE À FEU
ARRIÈRE, CÔTÉS ET BASE DE L'APPAREIL	0 PO. (0 mm) DES ESPACERS

* VOIR LE MANUEL D'INSTALLATION POUR AUTRES HAUTEURS VS PROFONDEURS DE LA TABLETTE. LES MATÉRIELS COMBUSTIBLES NE SONT PAS PERMIS SUR LA FAÇADE DE L'APPAREIL. LE PROLONGEMENT DE L'ÂTRE INCOMBUSTIBLE DOIT ÊTRE DE 18 PO. (457 mm) DE PROFONDEUR PAR 42 PO. (1070 mm) DE LARGEUR MINIMUM SUIVANT LES SPÉCIFICATIONS DU MANUEL D'INSTALLATION.

PIÈCES REQUISES POUR L'INSTALLATION:

- TUYAU FLEXIBLE DE 4 PO. OU 5 PO. (102 OU 127 mm) DE DIAMÈTRE ET PRISE D'ENTRÉE D'AIR.
- UTILISER UNE CHEMINÉE EXCEL 7 PO. (178 mm) DE DIAMÈTRE DE ICC ET SES COMPOSANTS HOMOLOGUÉS SELON LES INSTRUCTIONS D'INSTALLATION.

VOIR LES INSTRUCTIONS D'INSTALLATION DU MANUFACTURIER POUR LES COMPOSANTS OPTIONNELS: VENTILATEURS, SYSTÈME D'ÉVENT PAR GRAVITÉ ET ACCESSOIRES DE CHAUFFAGE CENTRAL. SEULES LES OPTIONS ORIGINALES DE RSF DOIVENT ÊTRE UTILISÉES ET ACHETÉES PAR L'ENTREMISE DE DÉTAILLANTS RSF.

AVERTISSEMENT: CE FOYER N'A PAS ÉTÉ TESTÉ AVEC UNE BÛCHE À GAZ SANS ÉVÈNT. POUR RÉDUIRE LES RISQUES DE FEU ET DE BLESSURES, NE PAS INSTALLER DE BÛCHE À GAZ SANS ÉVÈNT DANS CE FOYER.

LE REMPLACEMENT D'UNE VITRE DOIT SE FAIRE AVEC UNE VITRE CÉRAMIQUE DE 5 mm D'ÉPAISSEUR SEULEMENT. OPÉRER SEULEMENT AVEC LES PIERRES RÉFRACTAIRES EN PLACE. POUR UTILISATION AVEC DU BOIS SEULEMENT: NE PAS SURCHAUFFER L'APPAREIL.

CET APPAREIL AU BOIS CONTIENT UN CATALYSEUR QUI DOIT ÊTRE INSPECTÉ PÉRIODIQUEMENT ET REMPLACÉ RÉGULIÈREMENT POUR FONCTIONNER CORRECTEMENT. RÉFÉREZ-VOUS AU MANUEL DU PROPRIÉTAIRE POUR PLUS D'INFORMATIONS. IL EST INTERDIT PAR LES LOIS FÉDÉRALES D'OPÉRER CET APPAREIL AU BOIS SANS RESPECTER LES CONSIGNES D'OPÉRATION DU MANUEL DU PROPRIÉTAIRE OU SI LE CATALYSEUR EST DÉACTIVÉ OU ENLEVÉ.

CET APPAREIL AU BOIS N'EST PAS APPROUVÉ AVEC UN REGISTRE DE CHEMINÉE AUTRE QU'UN REGISTRE OUVERT-FERMÉ.

UL
3 PARTY US-CA
ACCREDITED US-CA
MH-1405
CERTIFIED

FRÉPARE: RRE CH AMBER
FOR USE WITH ICC CERTIFIED
MODEL RESIDENTIAL TYPE
APPLIANC EC HINNEY

NUMBER



SERIAL NO. / NO DE SÉRIE

DATE MANUFACTURED
DATE DE FABRICATION

MANUFACTURED BY /
FABRIQUÉ PAR:
ICC, 400 J.F. KENNEDY,
ST-JEROME, Q.C.,
CANADA, J7Y 4B7



MADE IN CANADA
FABRIQUÉ AU CANADA

COMPLETE OPTIONS LIST

 FIREPLACE OPTIONS	⚡											
	Electricity required	DELTA FUSION	FOCUS 250	FOCUS 320	Focus 320 SBR	FOCUS ST	OPEL2 & OPEL3	OPEL+ 2C & OPEL+ 3C	OPEL+ KEYSTONE	PEARL		

MANDATORY LOUVER/CLEAN FACE SELECTION												
UL127 & ULC-S610 Listed												
FO-F2	Clean Facing - 8" Intake (Req. 2 Gravity Vent Kits)				✓	✓		✓				
FO-F3	Clean Facing - 10" Intake (Req. 2 Gravity Vent Kits)								✓			
FO-F320SBR LB	F320SBR - Louver Assembly - Black					✓						
FO-F320SUR	Decorative Surround 60"				✓							
FO-OPLB	Opel - Louver Kit - Black							✓	✓			
FO-OPLC	Opel - Decorative Grills							✓	✓			
FO-OPLK	OPPK - Keystone Louver										✓	
FO-OPLT	Opel Top Louver Trim							✓	✓			

OPTIONAL FIRESCREENS												
UL127 & ULC-S610 Listed												
FO-FDFS	Firescreen - Opel								✓	✓		

OPTIONAL GRAVITY VENT KITS												
UL127 & ULC-S610 Listed												
FO-D	Gravity Vent Damper								✓	✓		
FO-DUCT5	Insulated Duct 5 feet		✓	✓	✓	✓	✓	✓	✓	✓	✓	✓
FO-V2	Gravity Vent Kit		✓	✓	✓	✓	✓	✓	✓	✓	✓	✓
FO-V3	Gravity Vent Kit (Rectangular)		✓	✓	✓	✓	✓	✓	✓	✓	✓	✓
FO-VGC	Contemporary Gravity Vent Grill		✓	✓	✓	✓	✓	✓	✓	✓	✓	✓

OPTIONAL FAN SELECTION												
UL127 & ULC-S610 Listed												
FO-CIF	Inline Fan	⚡		✓	✓	✓			✓			
FO-FDHB5-N	Internal Blower Kit - double	⚡	✓		✓	✓			✓	✓	✓	
FO-FDHB6-1	Central Heat Blower	⚡	✓		✓	✓			✓	✓	✓	
FO-FDHB8	Internal Blower Kit - single	⚡										✓
FO-HD	Heat Dump	⚡		✓	✓	✓			✓	✓	✓	✓



FIREPLACE OPTIONS

⚡ Electricity required										
	DELTA FUSION	FOCUS 250	FOCUS 320	Focus 320 SBR	FOCUS ST	OPEL2 & OPEL3	OPEL+2C & OPEL+3C	OPEL+KEystone	PEARL	

OPTIONAL ADDITIONAL ACCESSORIES

UL127 & ULC-S610 Listed

FO-FDHC4	Thermostat Kit	⚡			✓			✓	✓	✓
FO-FDHC6	Central Heating Control (with FO-FDHB6-1)	⚡	✓		✓	✓		✓	✓	✓
FO-FDHC6-1	Back Draft Damper		✓		✓	✓		✓	✓	✓
FO-FDHCZ1	Zone Heating Control (with FO-FDHB6-1)	⚡	✓		✓	✓		✓	✓	✓
FO-FDHCZ2	Zone Definition Kit (with FO-FDHB6-1)	⚡	✓		✓	✓		✓	✓	✓
FO-T	Central Heating Tee Option		✓		✓	✓		✓	✓	✓

MISCELLANEOUS OPTIONS

UL127 & ULC-S610 Listed

FO-AP	Ash Pan - Regular							✓	✓	✓
FO-CID	Intake Duct Kit - 6" (necessary for FO-CIF)			✓						
FO-FDCCO	Opel Catalytic Kit							✓		
FO-FDM7	Brick Chimney Adapter - 7"			✓	✓	✓		✓	✓	✓
FO-FDM8	Brick Chimney Adapter - 8"		✓					✓		

MISCELLANEOUS OPTIONS

Not listed - No impact on safety

FO-A	Decorative Log Retainer Cap		✓	✓	✓	✓	✓	✓	✓	✓	✓
FO-BRE	Bypass Rod Extension								✓		
FO-DTD	Digital Temperature Display								✓	✓	
FO-FDS45	45° Nailing Bracket		✓								
FO-INT	Outside Air Kit - 4" diameter		✓	✓	✓	✓	✓	✓	✓	✓	✓
FO-KDF	Rock Retainer Kit - Delta Fusion		✓								
FO-KF320	Rock Retainer Kit - F320 & F320SBR				✓	✓					
FO-KK	Rock Retainer Kit - Keystone										✓
FO-KN	Rock Retainer Kit - Onyx2/F320				✓						
FO-KP3	Rock Retainer Kit - Opel2/+2C/Opel3/+3C							✓	✓		
FO-KR	Rock Retainer Kit - Focus ST							✓			
FO-PDTB	Opel3 - Decorative Trim - Black							✓	✓		
FO-PDTG	Opel3 - Decorative Trim - Gold							✓	✓		
FO-PDTP	Opel3 - Decorative Trim - Pewter							✓	✓		

CONFIGURED OPTIONS LIST

Blocked Top Louver OPEL+ KEYSTONE	Required	Optional	Not available
Gravity Vent Kit	FO-V2 or FO-V3 (2)		
Ash Pan Kit		FO-AP	
Blower - Internal		FO-HB9	
Blower – Central Heat		FO-FDHB6-1*	
Thermostat kit (must be installed before facing and must be accessible for servicing)		FO-FDHC4	
Heat Dump Kit		FO-HD	
Rock Retainer Kit		FO-KK	
Central Heat T Option		FO-T	

Louvered OPEL+ KEYSTONE	Required	Optional	Not available
Opel Keystone Top Louver	FO-OPLK		
Ash Pan Kit		FO-AP	
Blower - Internal		FO-HB9	
Blower - Central Heat		FO-FDHB6-1*	
Thermostat kit		FO-FDHC4	
Heat Dump Kit		FO-HD	
Rock Retainer Kit		FO-KK	
Gravity Vent Kit		FO-V2 or FO-V3 (1 or 2)	

* Possible add-ons: FO-FDHC6, FO-FDHCZ1, FO-FDHCZ2

REPLACEMENT PARTS

**Will be available soon
Contact your RSF dealer for information**



LIMITED WARRANTY

30 Years Limited Warranty

All RSF Woodburning Fireplaces models are warranted against defects in material and workmanship for a period of 30 years, subject to the following conditions:

During the first year **RSF Woodburning Fireplaces** will repair or replace, at our option, any parts which upon examination by an authorized **RSF Woodburning Fireplaces** representative, are found to be defective, except the parts listed in the EXCLUSIONS portion of this warranty. **RSF Woodburning Fireplaces** will also pay reasonable labor costs for the repair work.

During the second through fifth years **RSF Woodburning Fireplaces** will repair or replace, at our option, any parts which upon examination by an authorized **RSF Woodburning Fireplaces** representative, are found to be defective, except the parts listed in the EXCLUSIONS portion of this warranty. **RSF Woodburning Fireplaces** shall not be responsible for any labor costs associated with this repair work.

During the sixth through thirtieth years **RSF Woodburning Fireplaces** will provide replacement parts, if available, at 50% of the published retail price, except for the parts listed in the EXCLUSIONS portion of this warranty. **RSF Woodburning Fireplaces** shall not be responsible for any labor costs associated with this repair work.

EXCLUSIONS:

- Electrical components are warranted for one year only.
- Glass and plating.
- Damage due to normal wear and tear, such as paint discoloration, worn gaskets, eroded or cracked refractory components.
- Repairs or replacements necessitated by vandalism, neglect, abuse, over-firing, improper fuel or fuel loads, or failure to adequately service the unit, as stated in the owner's manual.
- Repairs or replacements (particularly charges for travel and labor) not authorized by **RSF Woodburning Fireplaces** in advance.

LIMITATIONS:

- All items found to be defective will be replaced or repaired upon return of the defective part to an authorized **RSF Woodburning Fireplaces** dealer. **RSF Woodburning Fireplaces** will not be responsible for freight costs related to shipping replacement parts.
- Any complete fireplace, or part thereof, that is replaced or serviced under this warranty, will be warranted for a period not exceeding the remaining term of the original warranty.
- This warranty is not transferable.
- This warranty does not apply to damage to the appliance while in transit.
- This warranty does not apply if the installation does not conform to the installation requirements in the owner's manual.
- The Catalytic Combustor is under warranty by RSF Woodburning Fireplaces for five (5) years from the date of original retail purchase. The purchaser shall pay the following share of the then current retail price for the combustor: the first two (2) years no charge, 3rd year 60%; 4th year 70%, 5th year 80%. The Catalyst must be returned to your dealer along with a completed Combustor Failure Report (available online on RSF website under the warranty section) and original proof of purchase document.

RSF Woodburning Fireplaces is free of liability for any damages caused by the appliance, as well as material and labor charges incurred in the removal or re-installation of any **RSF Woodburning Fireplaces** fireplace under this warranty. Incidental or consequential damages are not covered by this warranty.

The remedies set forth herein are exclusive, and the liability of the seller shall not exceed the price of the fireplace or part thereof upon which the liability is based.

This warranty is expressly in lieu of all other warranties expressed or implied, including the warranties of merchantability and fitness for use and all other obligations or liabilities on the part of **RSF Woodburning Fireplaces**.