



FO-AP

Ash Pan for the Opel2

The ash pan is available only for the Opel2 fireplace with a bottom louver. The ash pan provides a convenient way of disposing of the fireplace ashes. Simply remove the plug from the firebox and sweep the ashes through the hole into the ash pan. When the ash pan is full, simply remove the ash pan through the bottom louver opening and dispose of the ashes safely.

INSTALLATION

The ash pan goes under the firebox behind the bottom louver.

1. Open the bottom louver completely.
2. Remove the round central firebrick. This firebrick is not required with the ash pan.
3. Remove the nut and bolt on the central plug of the firebox. The nut is a locknut so you will need to hold it tightly to unscrew the bolt. Remove the top and bottom plates, the nut and the bolt. These are no longer required.
4. Slide the ash pan support (13.AP.07.P) onto the two guides underneath the firebox (see Figure 1).
5. Using the self-tapping screw provided, attach the ash pan support to the ash pan guide by screwing through the pre-punched hole at the back of the ash pan support (see Figure 1).
6. Slide the ash pan (1.13.AP.02.P) onto the ash pan support.
7. Put the ash pan plug (1.13.#AP.01.CP) in the hole of the firebox
8. Close the bottom louver and you are ready to use the fireplace with the ash pan.

❖ **WARNING: MAKE SURE TO ALWAYS HAVE YOUR ASH PAN AND ASH PAN PLUG IN PLACE BEFORE LIGHTING A FIRE.**

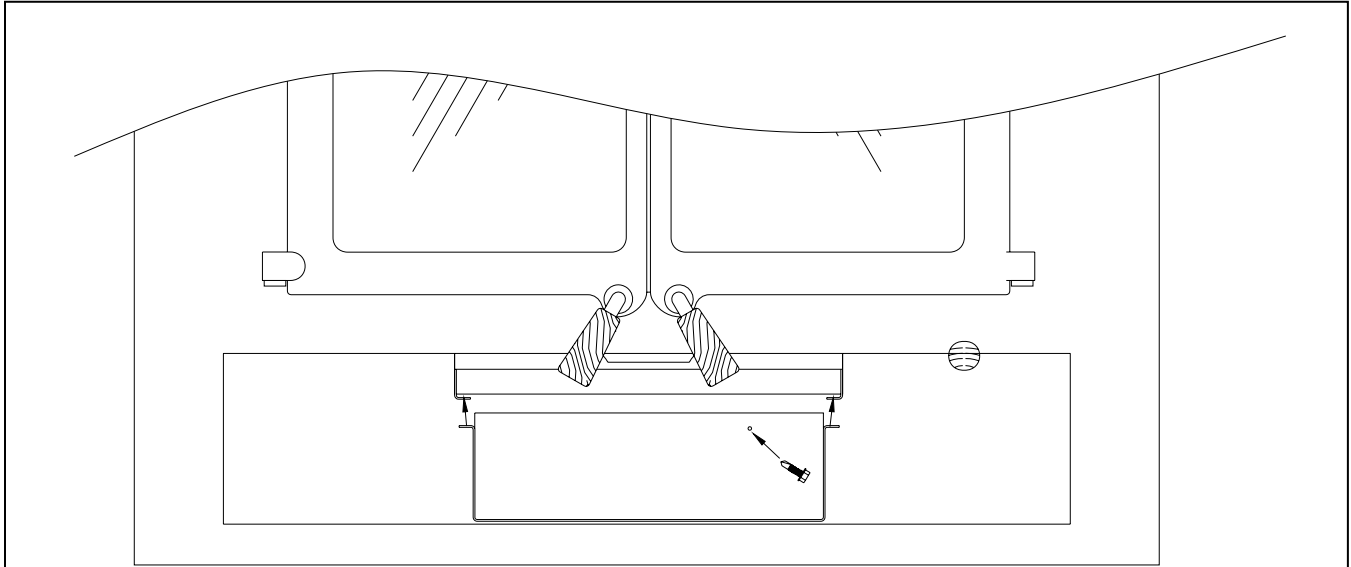

Figure 1 Installation du support pour le tiroir à cendres / Ash pan support installation

Liste de contrôle / Check List:

- 1 Support de tiroir à cendres / Ash pan support (13.AP.07.P)
- 1 Tiroir à cendres / Ash pan (1.13.AP.02.P)
- 1 Bouchon pour le tiroir à cendres / Ash pan plug (1.13.#AP.01.CP)
- 1 Sac contenant 1 vis auto-taraudeuse #8 x 1/2"(901009)
Bag containing 1 self-tapping screw
- Notice d'installation et liste de contrôle / Instructions and check list



**INITIALES
INITIALS**